

**TRANSLATION OF THE ORIGINAL  
OPERATING INSTRUCTIONS MANUAL**  
This manual must be always available for the user.  
Additional copies may be obtained on request.



**Index:**

1-Information for this manual.	4
2-Explanation of symbols used in this manual.	4
3-General.	5
3.1-Glossary and abbreviations used in this manual	5
4-Previous instructions and warnings.	6
5-Machine's description.	8
5.1-Area of application.	8
5.2-Equipment.	8
5.3-Main components.	9
6-Setting up.	10
6.1-Efforts due to suspended loads.	10
6.2-Configuration / dimensions	11
6.3-Wire rope installation.	12
6.4-Assembly of the platform	13
6.5-Running test.	22
7-Safety devices.	24
7.1-Hoist device.	24
7.2-Electric cabinet device.	24
7.3-Fall arrest device.	25
7.4-Overload safety device.	26
7.5-Upper limit switch.	26
7.6-Phase controller.	27
7.7-Emergency descent.	27
7.8-Acoustic and luminous bleeper.	27
8-Operating the platform.	28
8.1-Preliminary checks.	28
8.2-Rated capacity.	30
8.3-Use of the platform to work on blades.	30
8.4-Use of the platform to work on towers.	45
8.5-Electric controls.	47
8.6-No power emergency descent.	47
8.7-Action in case of fall arrest locking.	48
8.8-Request for help with the acoustic bleeper.	48
8.9-Platform's evacuation.	49
8.10-Removing the wire ropes.	50
8.11-Dismantling the platform.	51
8.12-Transport of the platform.	52
9-Residual risks not covered by the design of the platform.	53
10-Troubleshooting.	53
11-Maintenance.	56
11.1 Wire ropes	57
11.2 Elevator	57
11.3 Securichute fall arrest device	58
11.4 Traction device	58
12-Spare parts.	60
12.1-Modublade platform.	60
12.2-E.lift hoist.	60
12.3-Electric cabinet.	60
12.4-Securichute fall arrest device.	60
12.5-Traction device.	60
12.6-Nameplate and labels.	61
13-Disposal and environmental protection	62
14-Model for Declaration of Conformity.	63
15-Historic.	65
15.1-Diary inspection info.	66
15.2-Periodic inspection info.	67



**DANGER**

**Risk of wounds and injuries due to fall of objects, failure, incorrect application and / or incorrect utilization.**

Read the whole operating instructions manual before the assembly and set up of the platform. Follow the instructions and procedures described in this manual in order to ensure a safe utilization of the equipment.

**1-Information for this manual:**

<b>Date of edition:</b> 12th Edition: 03/2021	<b>Manufacturer:</b> <b>ACCESUS Plataformas Suspendidas, S.L.</b> C/Energia 54 08940 Cornellà de Llobregat, Barcelona -SPAIN Telf.: (+34) 93 475 17 73 www.accesus.es accesus@accesus.es
<b>Copyright:</b> All rights reserved.	

**2-Explanation of symbols used in this manual.**



**DANGER**

**Type and origin of danger**

Result: fatal or serious injuries.

-Solutions to eliminate the danger.



**IMPORTANT**

**Type and origin of danger**

Result: for example damage to machines or the environment.

-Solutions to eliminate any possibility of accidents.



**NOTE**

Useful tips for optimum working. Instructions to operation / documentation in writing.

### 3-General:

This operating instructions manual is destined to the workers of Modublade Temporary Suspended Platform. This operating instructions manual must be accessible to workers everytime. Request more copies if it's necessary.

ACCESUS Plataformas Suspendidas S.L. saves the rights to modify the product described in this manual as a part of his continued improvement.

The clients can obtain more information about other ACCESUS products throught address described at section 1. Please, check our website: [www.accesus.es](http://www.accesus.es).

#### 3.1-Glossary and abbreviations used in this manual:

**Wind turbine.**

A turbine having a large vaned wheel rotated by the wind to generate electricity.

**W.L.L.**

Working Load Limit

**Electrician.**

A professional worker who knows and has the correspondent and necessary qualification to know the risks and to avoid the danger that has an electrical environment.

**Worker.**

A person who works professionally with the machine.

**T.S.P.**

Temporary Suspended Platform.

**Exploiter.**

The responsible for both the regulatory operation of the installation of the device and compliance with maintenance intervals and repair works.

## 4-Previous instructions and warnings:

- TSP (Temporary Suspended Platforms) is destined exclusively to a **professional use**. Must be destined only to qualified people with knowledges for set up and utilization. Workers must be prepared for works at heights. Workers must know and assimilate the Law of Labor Risk Prevention.

- The machine must be dismantled and stored at the end of the works.

- For a safety utilization the TSP requires at least 2 workers at the same time.

- This TSP can only be used by authorized staff with adequate formation and psychologically suitable. Keep out from unauthorized people.

- Before to install and use a TSP is essential, for safety and efficiency, **to read and assimilate all the contents of this manual** and proceed in agreement to this instructions. Likewise, before the service, it's important to read all the labels fixed on the machine.

- This manual must be conserved in good condition and always be available for all workers.

- In case of loss or deterioration of the labels, these must be replaced before the use of the machine. Request more copies of the instructions manual and labels if it's necessary.

- The responsible company must apply the regulation of safety relative to the assembly, utilization, maintenance and technical controls referred to all the equipment. The responsible company must give the instructions to the workers and verify his aptitudes.

- Before putting in service the platform, the person in charge of work, must verify and ensure the good condition of the TSP equipment.

- Don't use a TSP or an accessory (wire rope, suspension points, etc.) in bad condition. A periodic control of the machine by an authorized person is essential for safety. The maintenance not described in this manual must be realized by the manufacturer or by an authorized repairer.

- Don't use the equipment for other uses than the indicated in this manual. The manufacturer can't guarantee the product for other configurations not described in this manual. For other applications consult the manufacturer or a professional specialized technician before proceeding to assembly the equipment.

- **Don't use the TSP beyond the limits of utilization** described in this manual and specially don't exceed the rated load of use indicated in the labels.

- The manufacturer declines any responsibility for the consequences of a disassembly of the devices, modifications or manipulations, specially in case of substitution of the original pieces by others from different origin.

- This TSP has a life of 10 years. This duration is based on a utilization of the platform of 200 hours per year and with the condition that the annual reviews effect.
- A special care is needed by dangers that will appear when the TSP is over water, public areas or where it's not possible to get the platform down to a safe position.
- Don't use the TSP in severe conditions such as atmospheric extreme conditions, corrosive environments, magnetic fields, explosive atmospheres (ATEX), works under tension, works in confined spaces, etc.
- Don't use the TSP for loads which can generate dangerous situations (for example: molten metal, acids, radioactive materials, etc.)
- For platforms employed at heights superior to 40 m they must limit the lateral movements by a guide system, composed by anchorages each 20 m. Consult section 8.3 and/or 8.4.
- A special care is needed by dangers that will appear when the loads are manipulated.
- **In some countries of the European Union is obligatory an inspection before the putting in service of a new work. This control must be realized by an authorized organism.**
- It performs vital importance to plan the work before beginning the works in a new tower and / or in every day. Especially to plan the suitable are for locate the materials in the base of the tower, the Nacelle's orientation, **check that the speed of the wind is never superior to 50 km/h (14 m/sec). In certain wind farms and / or wind turbine manufacturers suspended platform using wind speed limit is lower, 10m/seg.** Respect the limitation of the speed of the wind in the user's security plan if it's lower.

**IMPORTANT:**

If you entrust this equipment to subcontracted personnel you have to apply and check his obligations about safety at work, specially for verifications and tests before the putting in service.

## 5-Machine's description.

### 5.1-Area of application.

The machine described in this manual is destined to be used temporary for inspection and maintenance works for blades and tower of wind turbines (persons elevation and tools included).

The platform remains excluded for:

- Explosive atmospheres (ATEX).

### 5.2-Equipment.

The equipment described in this manual is composed by a TSP **Modublade** with an **e.lift 501** powered hoist and a **Securichute** fall arrest device suspended by wire ropes. These wire ropes are anchored to a system of "palonier" that allows the anchorage of the suspension wire rope, secondary wire rope and guide wire rope of the platform.

The limit of the equipment described in this manual are the anchorage rings from the 200028 wire rope suspension slings to nacelle's multiplier.

If this equipment does not addapt to your needs, ACCESUS can advise in the correct choice of a TSP for your specific case. If it's necessary we can design a bespoke solution for you.

The TSP includes all the safety devices to make a temporary suspended access installation covered by the declaration of conformity made by the manufacturer and according to the Machine Directive.



### 5.3-Main components.

The main components are:

**TSP Modublade**, composed by:

- 1-e.lift 501 powered hoist.
- 2-Securichute 600 fall arrest device,
- 3-Electric cabinet,
- 4-Suspension stirrup,
- 5-Front and side panels,
- 6-Floor panel,
- 7-Pads or rollers,
- 8-Anchorage for guide system,
- 9-Anchorage point for 2 people,
- 10-Anchorage point for descender,
- 11-Suspension and secondary wire ropes,
- 12-200028 wire rope suspension slings (one for each wire rope)
- etc.

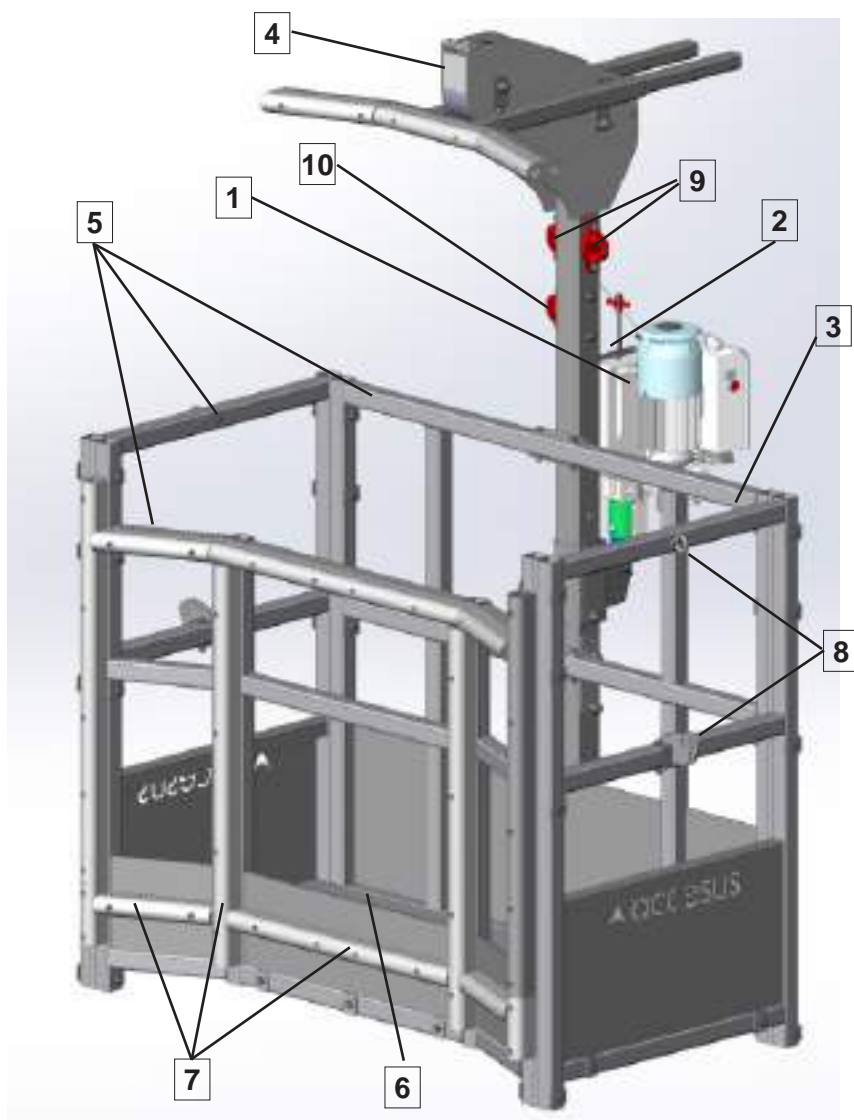

#### Accessories for the assembly:

- Wire rope winder,



## 6-Setting up.

### 6.1-Efforts due to suspended loads and recommendations of the point of suspension of the platform.

**The vertical reaction factored to the wire ropes traction is 15,00 kN.** It means that the anchorage point of each wire rope must be capable to support this load in the direction of the anchorage sling, which depends of the type of wind turbine.

A qualified person must be realize the calculations of load test and be the responsible of the structure's capacity to support the efforts due to the suspended loads.

There are many ways of anchoring the wire ropes to the wind turbine, depending on:

- wind turbine model,
  - zone of the shovel to access,
- etc.

In any case, slings 200028 should be used to anchor the wire ropes to the wind turbine and follow all the instructions in its instructions manual.

The images describe assembly examples.

The wind turbine points where the slings are anchored must meet all the following requirements:

- a) To have the minimum resistance indicated in the first paragraph of this section
- b) To be blocked and to have no possibility of displacement and / or rotation with the loads described.
- c) They must be structural or lifting points, such as, for example:
  - c1) Main axis,
  - c2) Lifting eyebolts of reducer or generator (with a minimum resistance of 1500kg in the direction of the load applied by the sling,)
  - c3) blade root,
  - c4) anchor bolts of the blades, etc

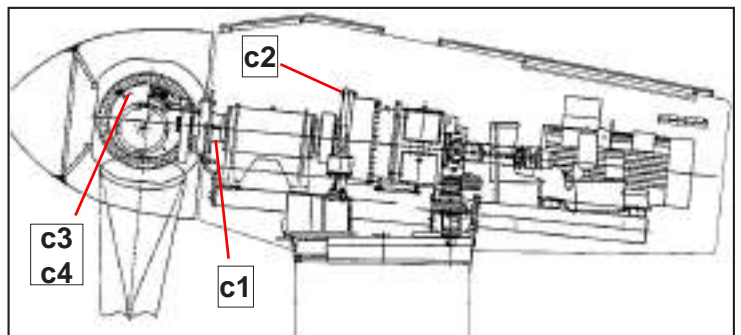

- d) Not to have sharp edges that could damage slings or suspension wire ropes.
- e) The installation and disassembly of the wire ropes is as safe and ergonomic as possible.

ACCESUS recommends a test load for each model of wind turbine in order to verify that the anchorage points are adequated. ACCESUS proposes this service and gives you a certification of the load test.

## 6.2-Configuration / dimensions.

Modublade is a suspended platform equipped with 1 e.lift501 powered hoist and 1 Securichute600 fall arrest device and all the accessories described at section 5.3.

### 6.2.1-Modublade 1,6m

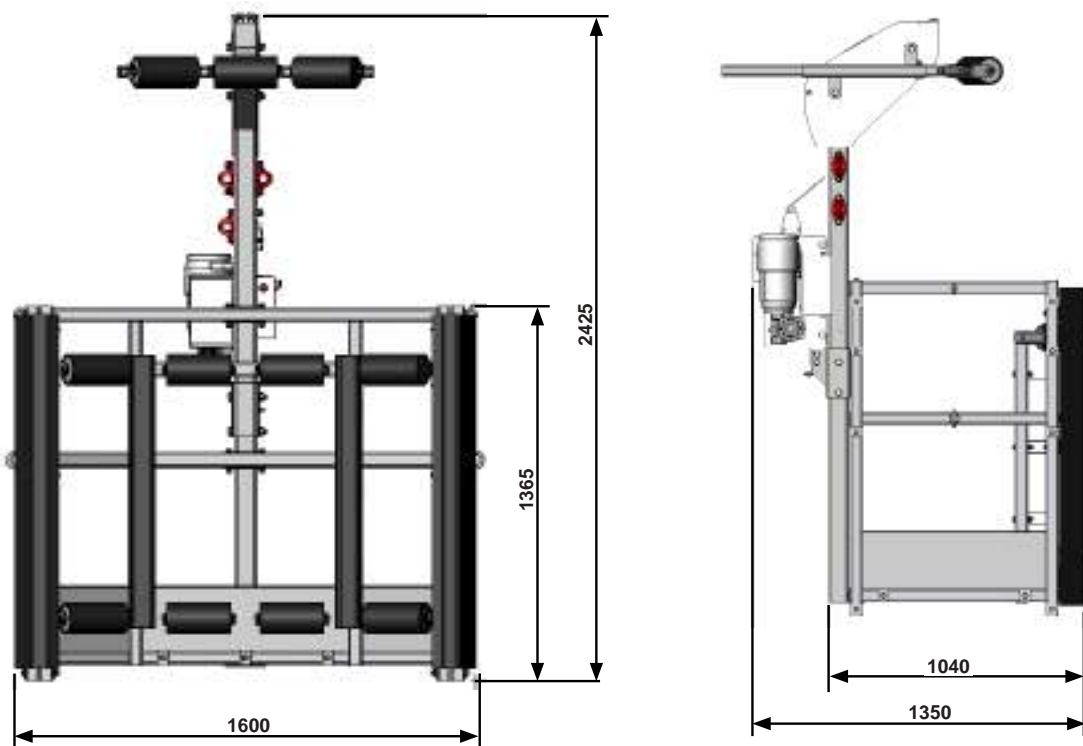

### 6.2.2-Modublade 2m

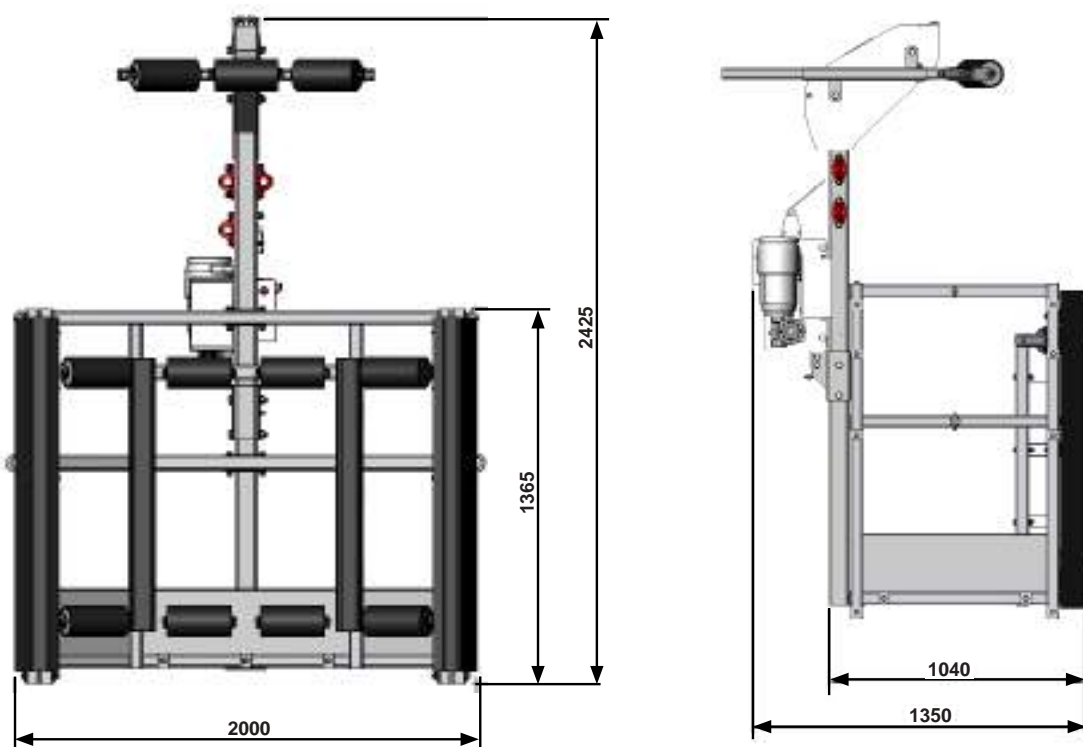

### 6.3-Wire rope installation.



**DANGER**

<p><b>Hurts for wire ropes manipulation.</b></p>	<p>Danger of cuts and scratches.</p>
<p><b>Risk of wounds and injuries due to fall of objects, fall from different level and / or breaks.</b></p>	<p>Danger of death due to fall of objects, fall from different level and / or breaks.</p>
	<p>-Before the assembly of the wire ropes ensure that the suspension structure has enough capacity to support the efforts of the suspended loads described at section 6.1.</p> <p>-Previous to the assembly and during the use of the platform, the wind turbine must be stopped and all necessary locks must be made to ensure that no movement of the wind turbine is possible.</p> <p>-Use adequate PPE's (Personal Protective Equipment): anticut protection gloves, safety boots, safety glasses, safety helmet and work clothes. Also mandatory PPE's according to windmill's safety manual.</p> <p>-Use only wire ropes specified by the manufacturer.</p> <p>-Ensure that the wire rope diameter is the same diameter than the specified in the e.lift501 hoist and securichute600 fall arrest device on his labels. Ensure that the wire rope length is enough to work and check the good condition of the wire rope's tip.</p> <p>-Avoid the formation of curls in the wire ropes.</p> <p>-Place the platform heavily under his suspensions.</p> <p>-Use an intercommunication system for a correct coordination of maneuvers between workers at the base of the tower and workers at placed at the nacelle.</p> <p>-To position itself on the fiber of the nacelle, workers must wear safety harness with shock absorber and hooks or retractable fall arrester and be tied to a nacelle's anchorage point.</p>

These indications are valid for the work cable, safety cable and main guide cable.

There are different wire rope installation procedures in wind turbines depending on the wind turbine model, blade area to be accessed, etc.

Installation of the wire ropes requires, at least, 2 people: one in the platform and the other one on the roof.

The person on the roof has to wear a safety harness attached to a resistant anchoring point.

1-Unroll the wire rope from the floor and pull them up on the roof with a rope or from the suspension by unrolling them in a controlled manner. **Never let the wire rope falls down from the roof.**

2-Each cable should be anchored to a different sling. Ensure that the hooks are correctly closed.

**It is essential to use two separate anchoring points.**

### 6.4-Assembly of the platform.

Modublade suspended platform can be transported and stored totally mounted, partially mounted or totally dismantled.

For long distance transport or long time storage, the platform can be stored in 2 european pallets: 1 for the platform and 1 for the hoist and the wire ropes.



#### IMPORTANT

<b>Risk of injuries for cuts, fall of objects, fall from different level and / or breaks.</b>	Danger of death due to fall of objects, fall from different level and / or breaks.
	-Before to assembly the platform ensure that the screws are 8.8 quality and nuts are DIN985 type. -Use PPE's such as safety anticut gloves, safety boots, safety helmet, safety glasses and work clothes.

Modublade TSP must be delivered assembled. If not, the assembly must be realized following the next steps.

List of materials and tools necessary for the assembly:

Torque and ratchet wrenches for M10, M12 and M16 hexagonal screws. 2 people.

Fasteners and torque setting (the next list is referenced at the assembly's description)

	Description	Torque setting
T1	DIN931 M10x130 8.8 Screw + DIN985 Nut + 2 DIN125 Washers	36Nm
T2	DIN931 M12x40 8.8 Screw + DIN985 Nut + 2 DIN125 Washers	62Nm
T3	DIN931 M16x130 8.8 Screw + DIN985 Nut + 2 DIN125 Washers	153Nm
T4	DIN931 M12x75 8.8 Screw + DIN985 Nut + 2 DIN125 Washers	62Nm
T5	DIN931 M12x80 8.8 Screw + DIN985 Nut + 2 DIN125 Washers	62Nm

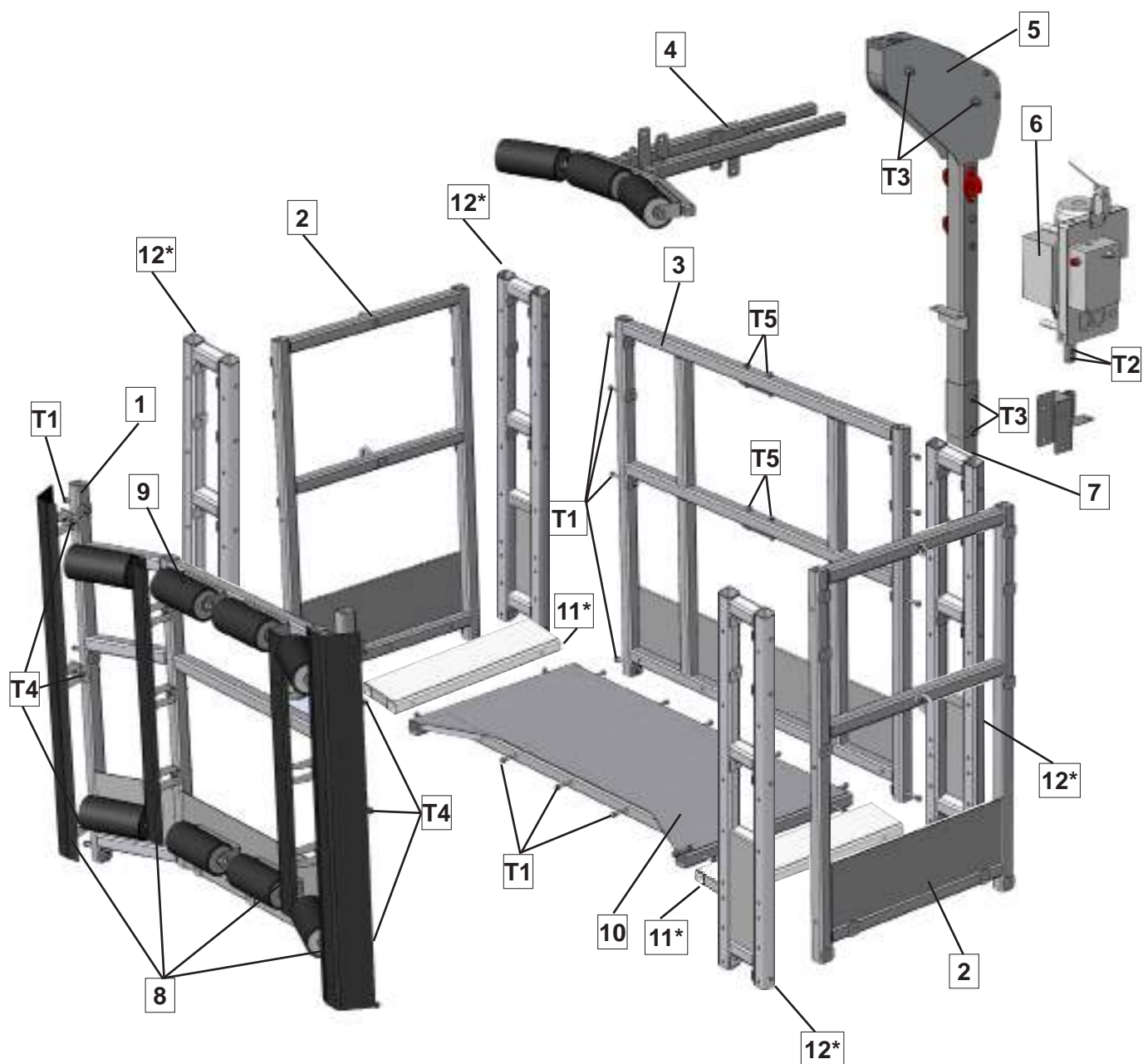

Pos.	Description	Quantity	Weight (kg)
1	Front side panel	1	35
2	End panel	2	10
3	Rear side panel	1	17
4	Support horn	1	17
5	Upper stirrup	1	20
6	Powered hoist	1	49
7	Stirrup base	1	7
8	Side protection	2	-
9	Roll	8	-
10	Floor panel	1	15
11	Floor panel 2m extension	2	3
12	Side panel 2m extension	4	5

\* Parts only for Modublade 2m configuration.

For platform's assembly follow the next steps:

1- Place the floor panel (10).

2a- For 1.6m modublade configuration: Assembly the Front side panel (1), Rear side panel (3) and End panels (2) with T1 fasteners. (Don't press yet).

2b- For 2m modublade configuration: For this assembly, a total of 4 Side panel 2m extension will be inserted between the front side panel and the end panels, and between the rear side panel and the end panels. In this case, 3 T1 screws will be added for each side panel 2m extension.

In the same way, a total of 2 floor panel 2m extensions will be inserted between the floor and the end panels. In this case, 2 T1 screws will be added for each floor panel 2m extension.

3- Assembly the stirrup (5) (7) to the hoist (6) with T2, T3 and T5 fasteners.

4- Now we have everything assembled except side protections and rolls. It's time to set the fastener's torque following the instructions from the table at page 17.

5- And finally assembly the Side protections (8) and Rolls (9).

6- Assemble the traction device and pulley of the secondary guidewire

Modublade suspended platform is already assembled

Here you can see a photographic description of the assembly step by step:









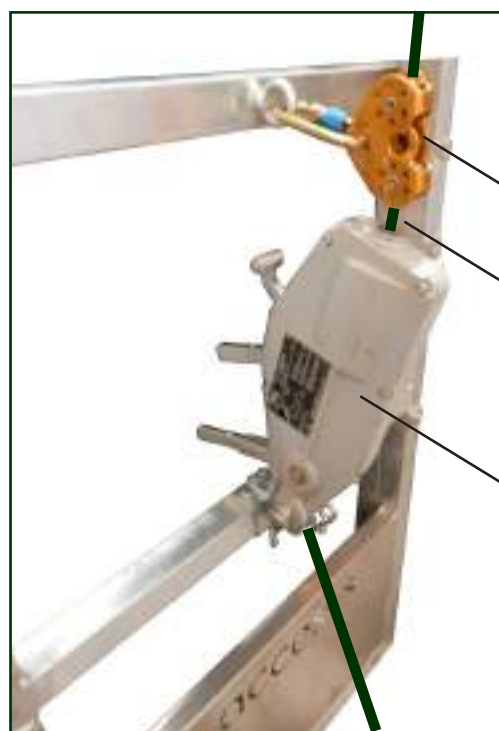

Deflection wire rope pulley

Secondary guide wire rope

Traction device

#### 6.4.1-Electric components.

The electrical connection must be made by the exploiter in accordance with EN 60204-32. Ensure that the power supply connector is compatible with the electric cabinet.

The power supply must be:

- Three-phase 400 V 50 Hz.
- Three-phase 400 V 60 Hz

- The power supply must be protected, before the connector, with a 16A differential circuit breaker 30 mA.

• The cable's gauge between the floor and the platform must be compatible with the power of the devices and the cable's length. See table:

Hose length	20 m	50 m	100 m	200 m
Three-phase 380-400V	1.5	1.5	1.5	2.5
Minimum cross-section in mm <sup>2</sup> (per wire) for one e.lift501 hoist				

- Put the electric cabinet at the front side panel.
- Connect the power supply cable from the electric cabinet to the power supply hose by means of a CEE 16A connector. The hose must be fixed to the platform with a pin. For superior heights to 100 m you have to verify the efforts admitted by the cable.
- Connect the e.lift hoist to the electric cabinet and check the correct running of the device. Before a working day is obligatory to check the stop emergency.
- The device is protected with a system of phase control relay. If this device doesn't work try to reverse the phases 180° with a screwdriver. See attached photo.
- Earth wire is done through the power supply line. The earthing function must be checked (check the protective cable and isolation). Optionally additional measures will be necessary.
- If necessary, a generator with a power equivalent to three times the rated power of the winch (nominal power of the generator [kVA] = number of winches x nominal capacity of the winches [kW] x 3) can be used. The generator must be grounded by the operator. The earthing function must be checked (check the isolation protection).



6.4.2-Introduction of the wire ropes in the platform.



**DANGER**

<p><b>Hurts for wire ropes manipulation.</b></p> <p><b>Risk of wounds and injuries due to fall of objects, fall from different level and / or breaks.</b></p>	<p>Danger of courts and scratches.</p> <p>Danger by catch.</p>	
	<p>Danger of death due to fall of objects, fall from different level and / or breaks.</p> <p>-Use safety gloves for manipulate the wire ropes.</p> <p>-Only use wire ropes specified by the manufactures.</p> <p>-Ensure that the wire rope's diameter is the same as indicated at the e.lif501 and securichute600 labels.</p> <p>-Ensure that the wire rope's length is enough for the height.</p> <p>-Ensure that the wire rope's tip is in good condition.</p> <p>-Avoid the loop's formation at the wire ropes when manipulating.</p> <p>-Place the platform in dead weight under the suspension.</p>	

6.4.2.1-Introduction of the suspension wire rope.

- 1- Seep the suspension wire rope into the pulley as we indicate at the image.
- 2- Introduce the wire rope's point into the elevator until the end.
- 3- Press "UP" button and continue pushing the wire rope until the hoist tows the wire rope for itself.
- 4- Press "UP" button until the wire rope gets slightly tight.
- 5- Roll carefully the rest of the wire rope in the reels, one for each cable

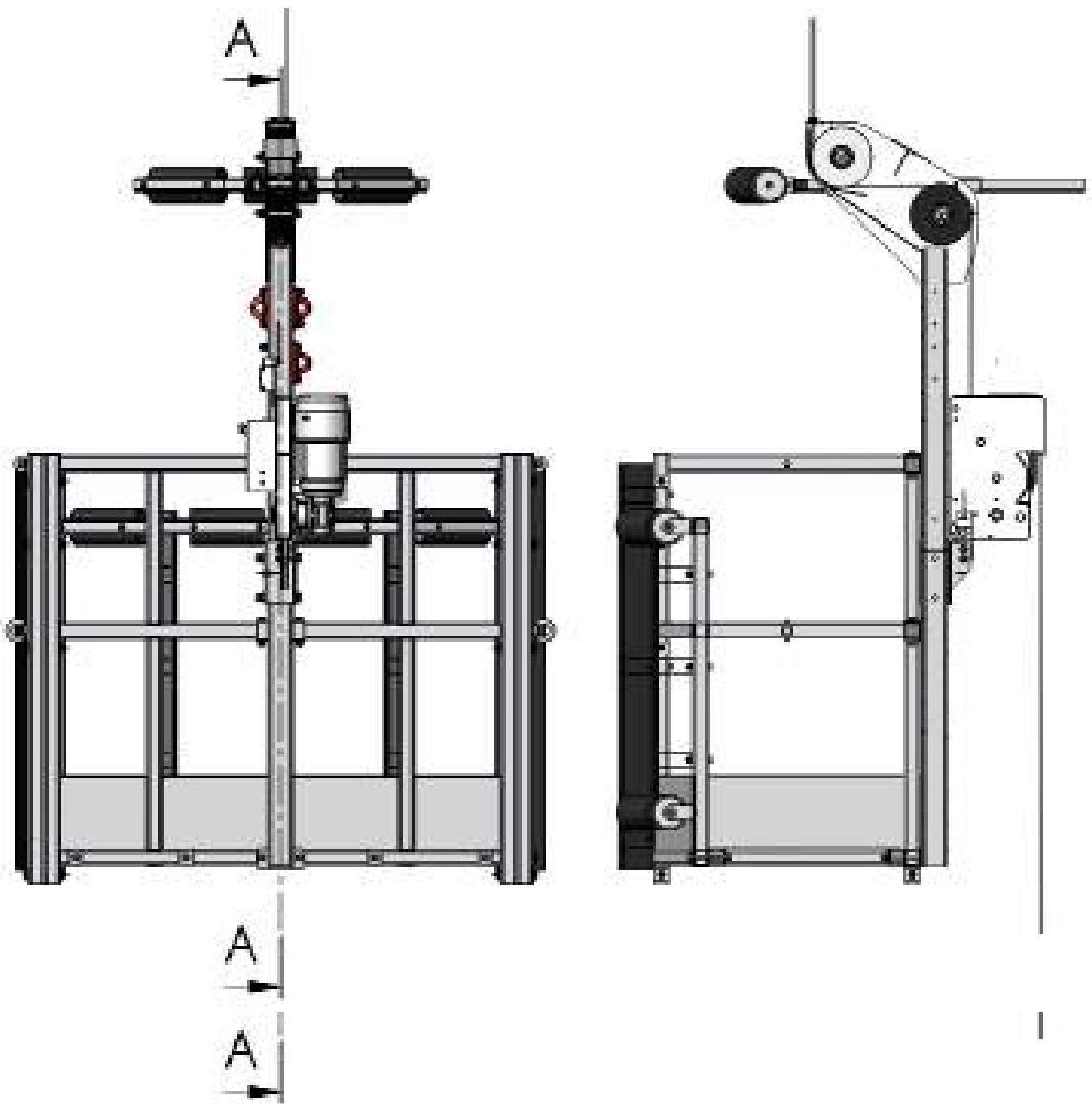

### 6.4.2.2-Introduction of the secondary wire rope.

- 1- Before to seep the secondary wire rope into the pulleys you have to verify that is not rolled with the suspension wire rope.
- 2- Seep the secondary wire rope into the pulley as we indicate at the image.
- 3- Block the stop emergency button, spin it.
- 4- Push down the reset handle.
- 5- Introduce the wire rope's tip into the fall arrest device, through guide cable, and tight it.
- 6- Fix a Grip' cable pin and a 20 kg Accesus counterweight to the suspension wire rope at 20 cm from the ground.
- 7- Unblock the stop emergency button, unspin it.

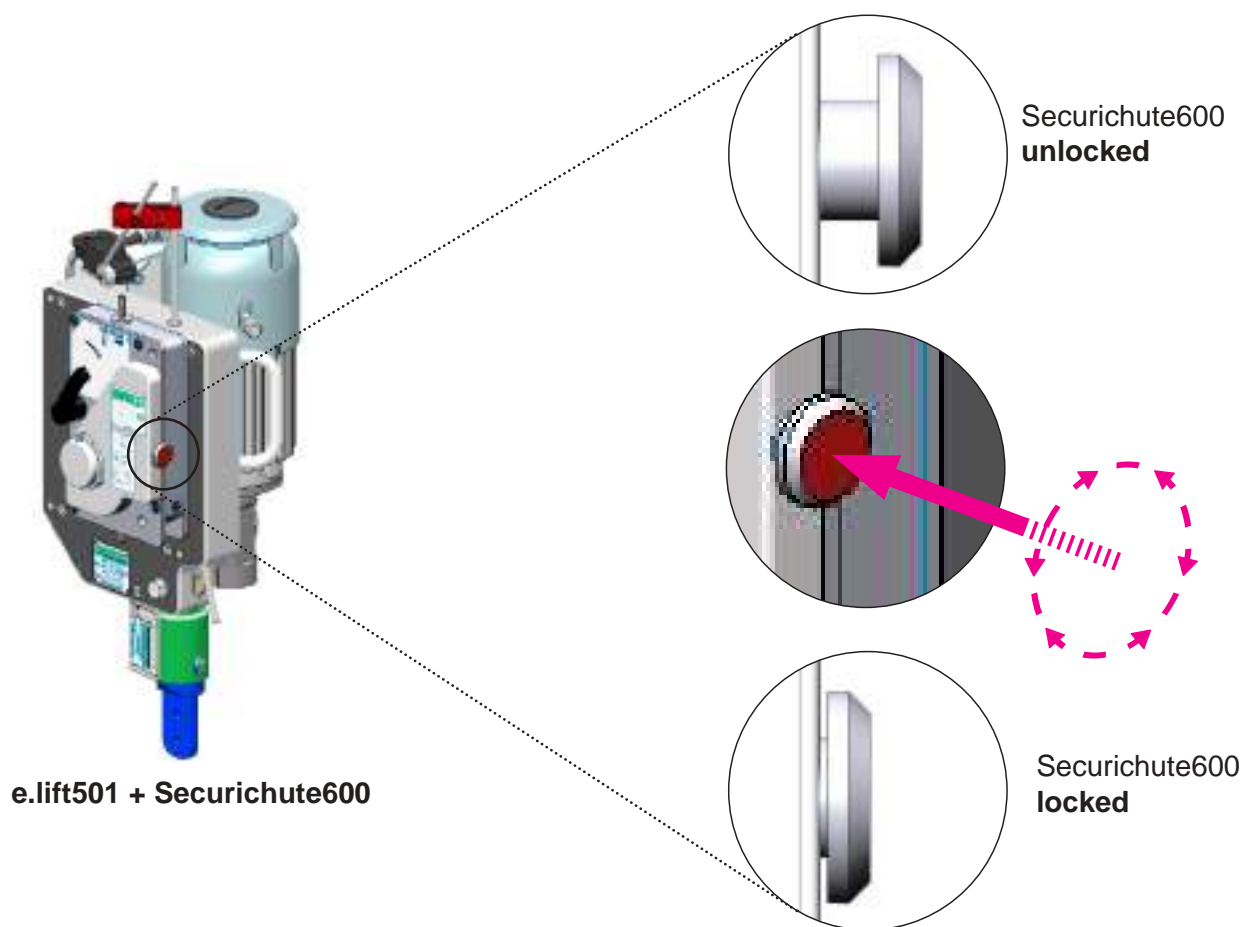

- 8- Roll carefully the rest of the wire rope.
- 9- To remove the wire rope remove the counterweight, push down the reset handle and pull up the wire rope slowly.

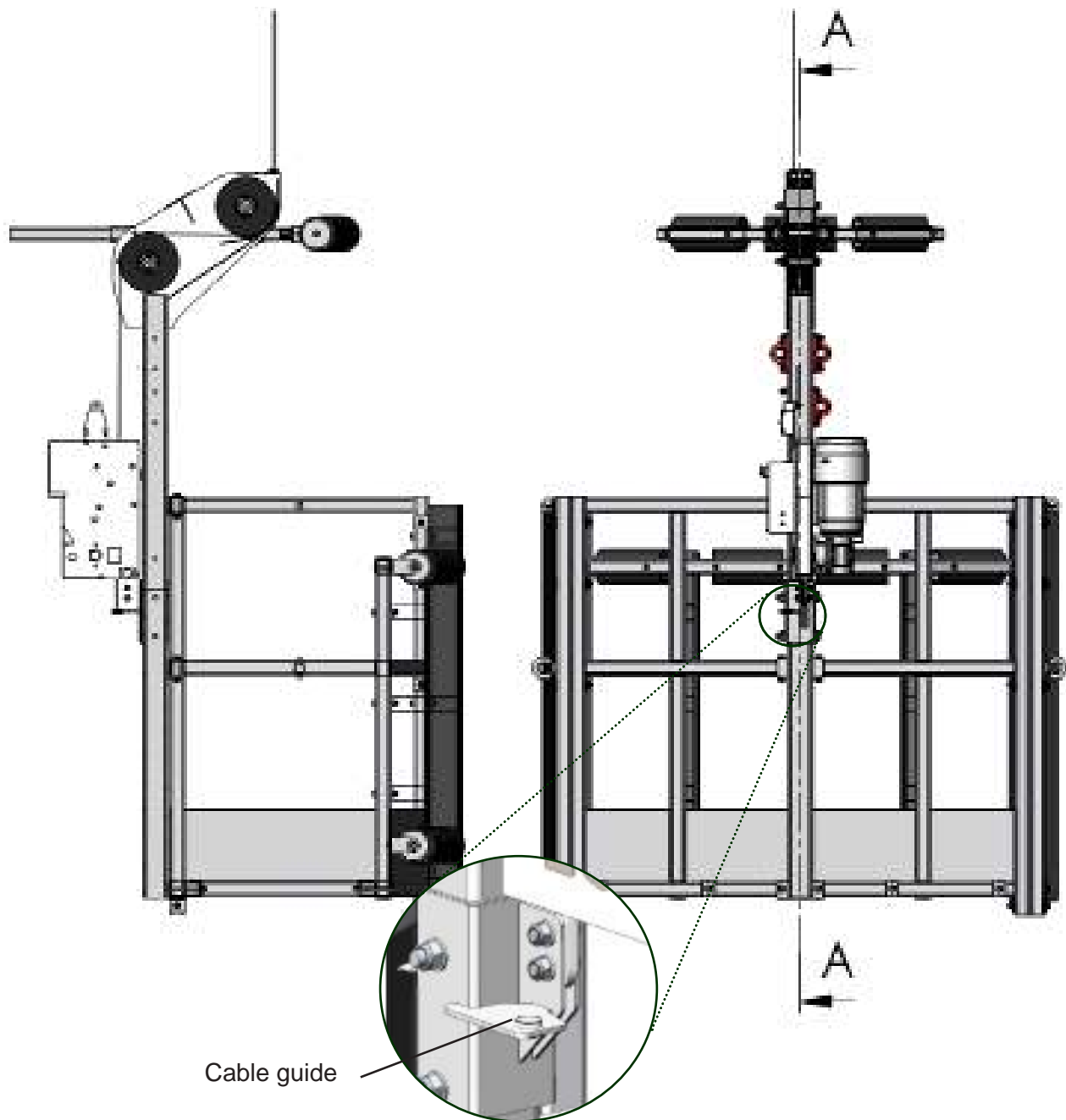

6.5-Running test



**DANGER**

**Risk of wounds and injuries due to fall of objects, fall from different level and / or breaks.**

Danger of death due to fall of objects, fall from different level and / or breaks.

-Do not stay under suspended loads.

-If necessary, block the danger zone.

When performing the following tests, the equipment must be loaded with the maximum load limit, in order to be able to check the operation of the safety devices.

6.5.1-Check the suspension point

-Make sure that the anchorage point of the anchoring slings has sufficient capacity to withstand the stresses due to suspended loads (See 6.1).

-Make a visual inspection of the anchoring slings and shackles. These must have the screw, nut and safety pin.

-Check visually that the latch of the wire rope hooks are correctly closed

6.5.2-Check the service brake

-Connect the lift upwards until the wire rope is tightened.

-Raise the load approximately 1m

-Stop the movement

-Scroll down

-Stop the movement

The stopping distance must not exceed 10cm. The lift must hold the load.

-Download the load and slacken the wire rope

-Stop the elevator

The elevator must hold the wire rope.

If the lift does not hold the load, the wire rope and / or the travel stop is greater than 10cm, have the elevator checked and repaired by ACCESUS or an authorized workshop by ACCESUS.

6.5.3-Check operation of emergency stop

-Connect the lift upwards until the wire rope is tightened.

-Press EMERGENCY STOP

The power supply to the motor must be switched off immediately. The elevator must hold the wire rope.

6.5.4-Check the operation of the securichute fall arrester (see section 11.3)

Verify that the securichute 600 ensures the attachment to the cable.

-Press the emergency button of the securichute 600. The jaws must close automatically and it must be impossible to pull the wire rope upwards manually.

-Rearm the securichute 600 by actuating the reset lever. The safety wire rope must be able to move freely through the securichute.

6.5.5-Check the operation of the detectors

**A**-Check the UPPER limit switch

-Display the limit switch manually.

-The upward movement must be stopped, the winch must hold the load and the descent must be possible.

**B**-Check the phase control relay, see section 7.6

If the phase control relay does not disconnect the drive when it is first connected and the drive is moved in the correct direction with the UP button, everything is correct. If the direction is not correct or the phase control relay disconnects the drive, use the phase inverter, see 7.6.

**End of the check:** Record the result of the checks in the log book.

## 7-Safety devices.

In order to guarantee a correct working order of the TSP and safety for the workers, the platform has the follow safety devices:

### 7.1-Hoist devices.

a) A brake system works in case of absence of electric supply or when the worker does not press the UP or DOWN buttons.

b) The electromechanical overload sensor stops the electric supply in case of overload at the platform or in case of setback during the ascend. The overload is indicated through the illuminated pushbutton located at the electric hoist.

c) The upper limit switch sensor stops the ascent when the bolt touches the upper limit.

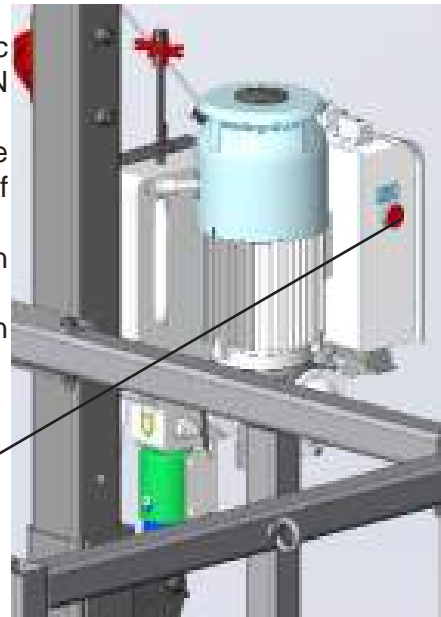

Overload illuminated pushbutton

### 7.2-Electric cabinet.

In case of emergency the platform's movement can be stopped immediately pressing the "STOP EMERGENCY" button (S0) located at the electric cabinet.

When the emergency has disappear spin the button, press the GREEN start button (S1), and after that the UP (S3) or DOWN (S4) buttons.

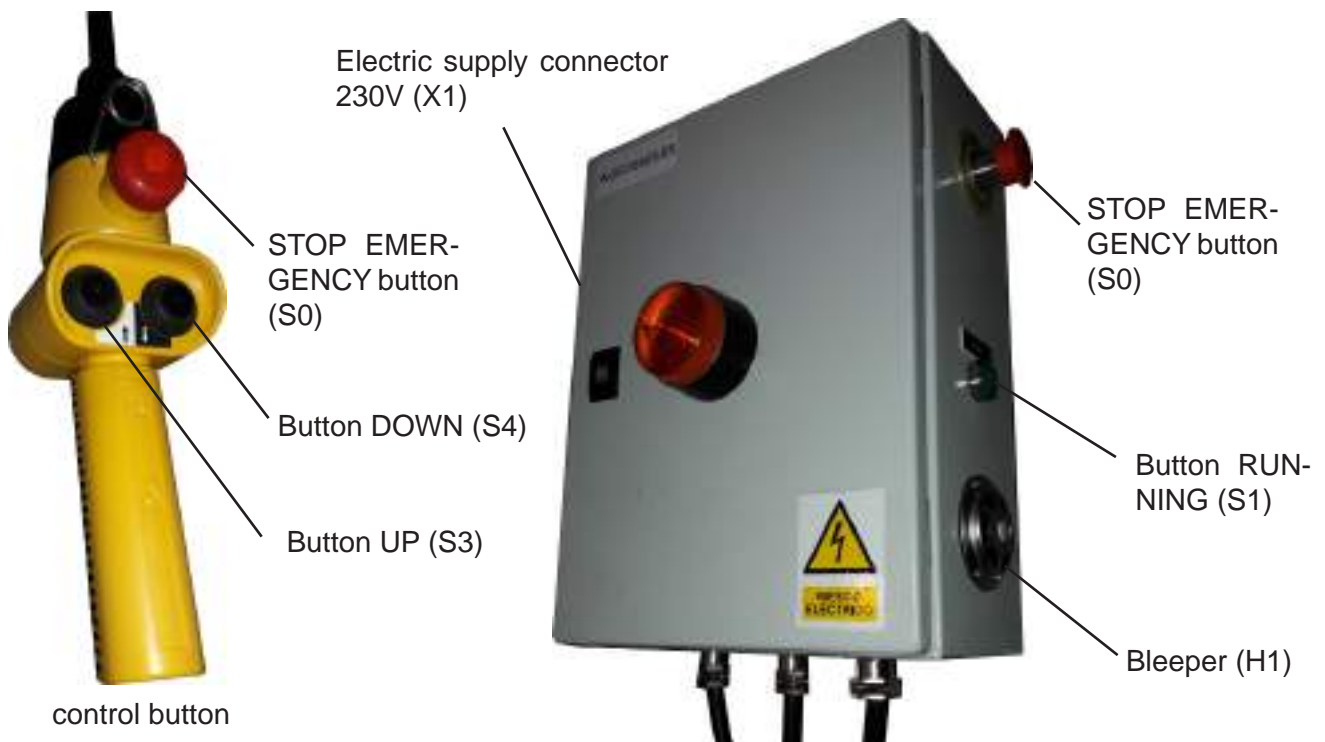

control button



### 7.3-Fall arrest device.

When the platform is running the secondary wire rope pass freely into the gags.

If the secondary wire rope is blocked it might be due to the following reasons:

- a) Rupture of the hoisting wire rope,
- b) Failure of the hoist
- c) Any problem with the hoist that causes an increase of the velocity,
- d) A crash,
- e) STOP EMERGENCY button is blocked,
- f) Gags not reset.

For a) and b) cases it's necessary to do a particular emergency operation. See section 8.8 of this user manual.

For c) d) e) and f) cases the worker must tense the suspension wire rope using the e.lift501 hoist. After that go up some centimeters, unblock the STOP EMERGENCY button and push the RESET handle of the securichute fall arrest device until his open position.

If the powered hoist glides, the worker can stop the platform pushing the STOP EMERGENCY button of the securichute fall arrest device.

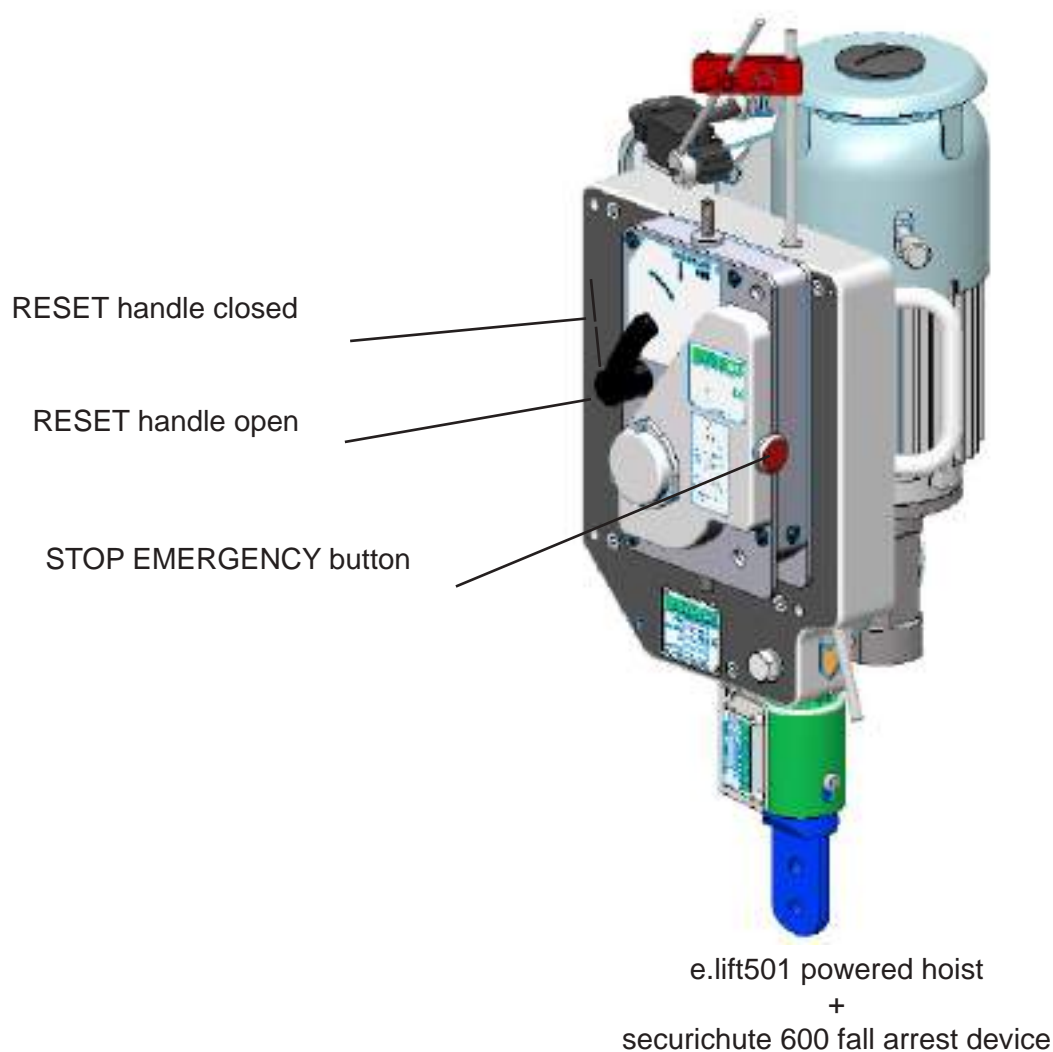

### 7.4-Overload safety device.

The overload safety device integrated at the hoist stops completely the platform in this cases:

- a) Overload or incorrect load distribution at the platform,
- b) The platform has an obstacle during the ascent.

An acoustic bleeper, placed at the electric cabinet, reports this overload.

If the platform has overload it's necessary to remove the load over the platform or the obstacle. After that it's necessary to press the overload iluminated pushbutton for a restart of the platform.

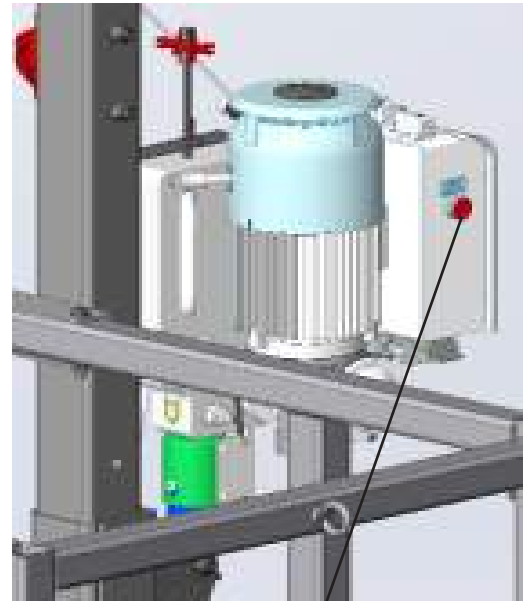

Overload iluminated pushbutton

**i NOTE**

If it is necessary to adjust the overload limit, request the procedure from Accesus by one of the means indicated in section 1

### 7.5-Upper limit switch.

The ascent of the platform stops when the upper limit switch touches the disc fixed at the wire ropes.

The descent continues being possible.

In case of error, this device has a second contact that stops all the platform's movements.

The upper limit switch must be installed under the hook of the suspension or secondary wire ropes.

### 7.6-Phase controller.

The three-phase equipments has a device which controls the direction of the phases. It is placed at the electric cabinet. This phase controller stops the power supply in case of an erroneous connection.

It's possible to invert the phases at the CEE connector by rotating 180° with a screwdriver.

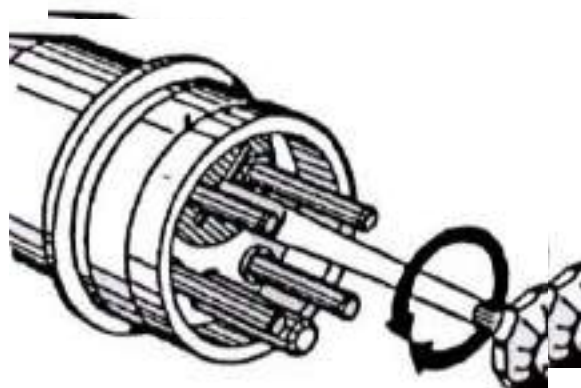

### 7.7-Emergency descent.

The powered hoists are equipped with a manual system that allows the descent of the platforms in case of no power supply.

The lever of emergency descent allows to descend with a controlled velocity in every moment.

### 7.8-Acoustic and luminous bleeper.

The platform is equipped with a luminous and flashing bleeper. It is ubicated at the hoist and indicates in every moment the position and movement of the platform.

The acoustic bleeper (H1) of the electric cabinet it can be use for a S.O.S. message or for advert to other workers. This sign runs when the EMERGENCY STOP button is blocked and pushing the RUNNING (S1) button.

## 8-Operating the platform.

### 8.1-Preliminary checks.

a) Use only wire ropes specified by ACCESUS. It is convenient to check that there is no dirt attached and, if so, clean it. It must be replaced if there are any damages such as described at section 11.1.1.

b) Check the correct functioning of the equipment according to section 6.8. Record the result of the checks in the record book.

c) Verify, visually, the safety of the suspensions at nacelle and ensure that all the components are there. Control specially the hooks and the wire rope's fixation. Such as:

- (1) 200028 Accesus wire rope suspension sling Ø14mm
- (2) 1.8T shackle with nut and pin.

Check especially the nut and the pin of the shackle and hook and the fixation of the lifting and safety wire ropes.

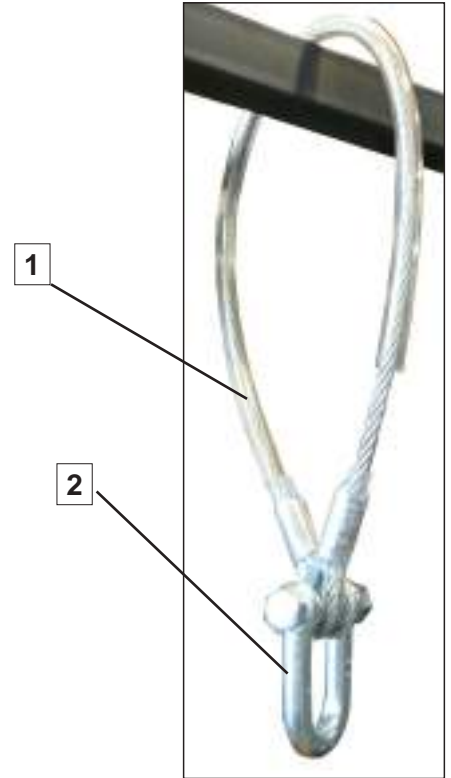

d) Ensure, through visual verification, that the suspensions are in dead weight with the platform.

e) Ensure that the load over the platform not exceeds the weight load limit including snow, ice, materials...

f) The workers at the platform must wear harness and be anchored to a point, one for each person. It is obligatory.

All the workers must be equipped with all the necessary PPE's, at least:

- Harness,
- 1.5 m sling with shock absorber,
- Safety gloves,
- Safety boots,
- Helmet,
- Emergency descender with enough rope to descend to the ground or safe area. (1 per platform),
- Adequated work clothes.

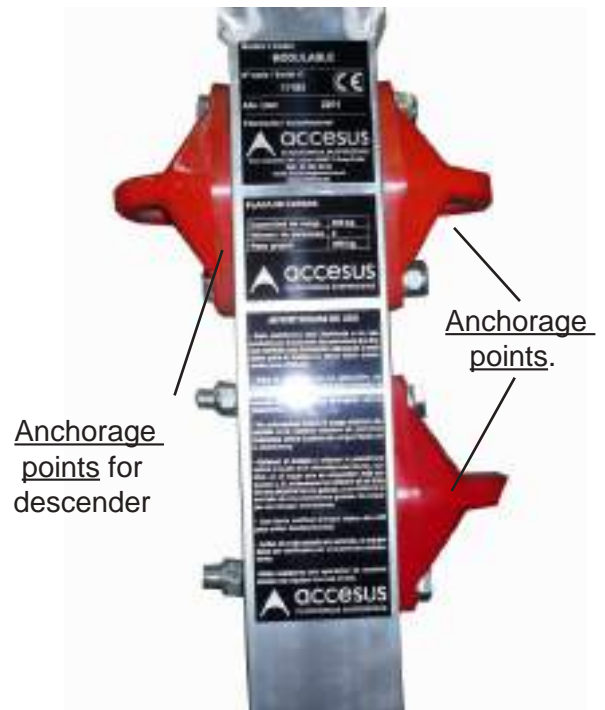

g) It is obligatory to sign correctly the floor's area susceptible of objects fall (tools, materials...) used at the platform and under the guide wire rope as well.

h) The equipment is destined to be used in luminous areas (natural or artificial). In case of use artificial illumination, the worker must dispose with enough light.

i) Ensure that the wind turbine is blocked, blade's position in vertical and that it could not be started by telematic devices.

j) Ensure that the temperature of the environment is over  $-10^{\circ}\text{C}$  and under  $+55^{\circ}\text{C}$ .

k) Don't work in case of hard wind (superior to 14 m/sec) or storm.

l) When the work is finished, the responsible of the work must place the platform out of service and switch off the power supply.

**It is forbidden to:**

- a) Use the platform with no secondary wire rope and no Securichute fall arrest device.
- b) Deactivate the safety devices (overload, upper limit switch...)
- c) Overload the platform.
- d) Loads over the people.
- e) Descend the platform manually with the brake of the e.lift hoist when the powered descent is possible.

**In some countries of the European Union is obligatory an exam of the comissioning, before the works, by an authorized organism.**

### 8.2-Rated capacity

**IMPORTANT**

The loads are calculated like this:

-The first person is calculated with a weight of 80 kg + 40 kg for tools and materials. The second person is calculated with 80kg.

The load must be distributed uniformly all over the platform

**LOAD CAPACITY**

Length (m)	1,6	2
Load capacity (kg)	300	250
Number of people	2	2
Dead weight (kg)	200	230

### 8.3-Use of the platform to work in blades

**For platforms working at heights superior to 40m in areas exposed to wind, the lateral movements must be controlled through an adequate retention system.**

Modublade suspended platform includes components for guide and support that allows to work all over the blade's surface safely and comfortably. Here is the description of the components:

1-Main guide wire rope. Anchored to the nacells resistance point (1T), placed at the nacelle to a lower anchorage point (usually vehicle) at the base of the tower.

2-Secondary guide wire rope. With a manual winch located at the platform it adjusts the distance between the platform and the main guide wire rope.

3-Bumpers. The platform is equipped with protection bumpers or support rolls that protect the wind turbine's blade from scratches.

4-Support horn for the wind turbine's blade which allows support from the platform to the blade when the platform is under the blade's tip.



Rolls protection suspended platform

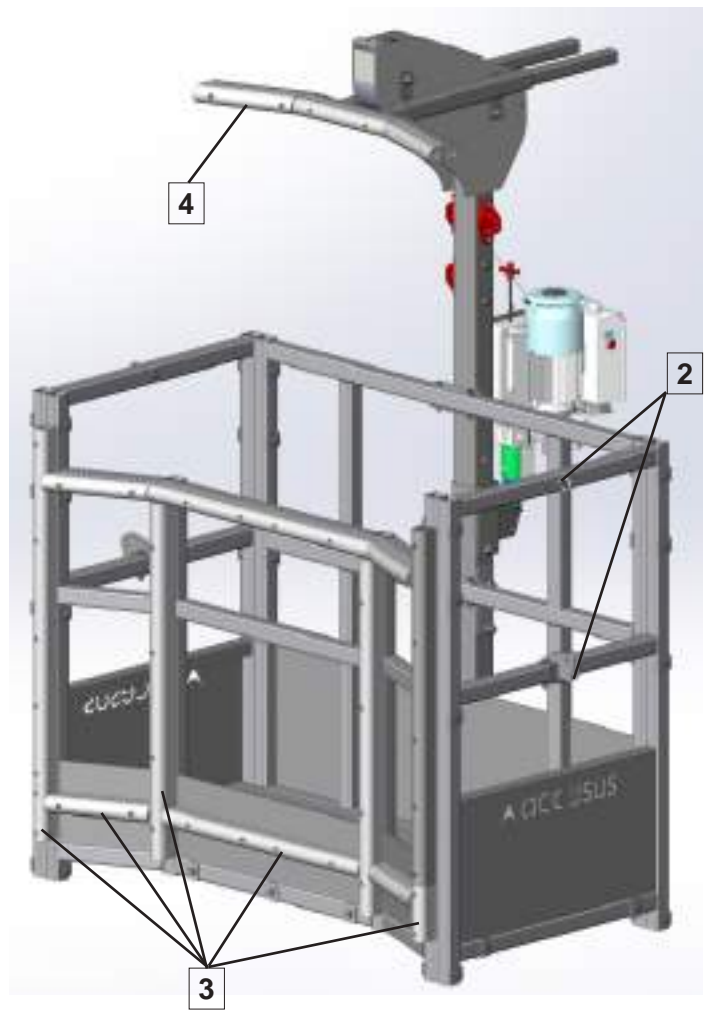

Bumpers protection suspended platform

### 8.3.1-Main guide wire rope tighten.

This is the situation: the wire rope are suspended (optionally from the palonier in some cases), suspension and secondary wire ropes installed at the platform and the guide wire rope with no tension and fixed through the traction device to the vehicle. If not see section 6.2.

In order to improve the platform's guide is recommended that the distance from the tower to the guide wire rope's anchorage be the longest possible. **A "d" distance similar to or greater than the tower height "H" is recommended.**

The tension for the guide wire rope must be realize manually by means of un dispositif de traction, with a pre-tension about 20-25 kg. The aspect of the wire rope must be similar to the next image:

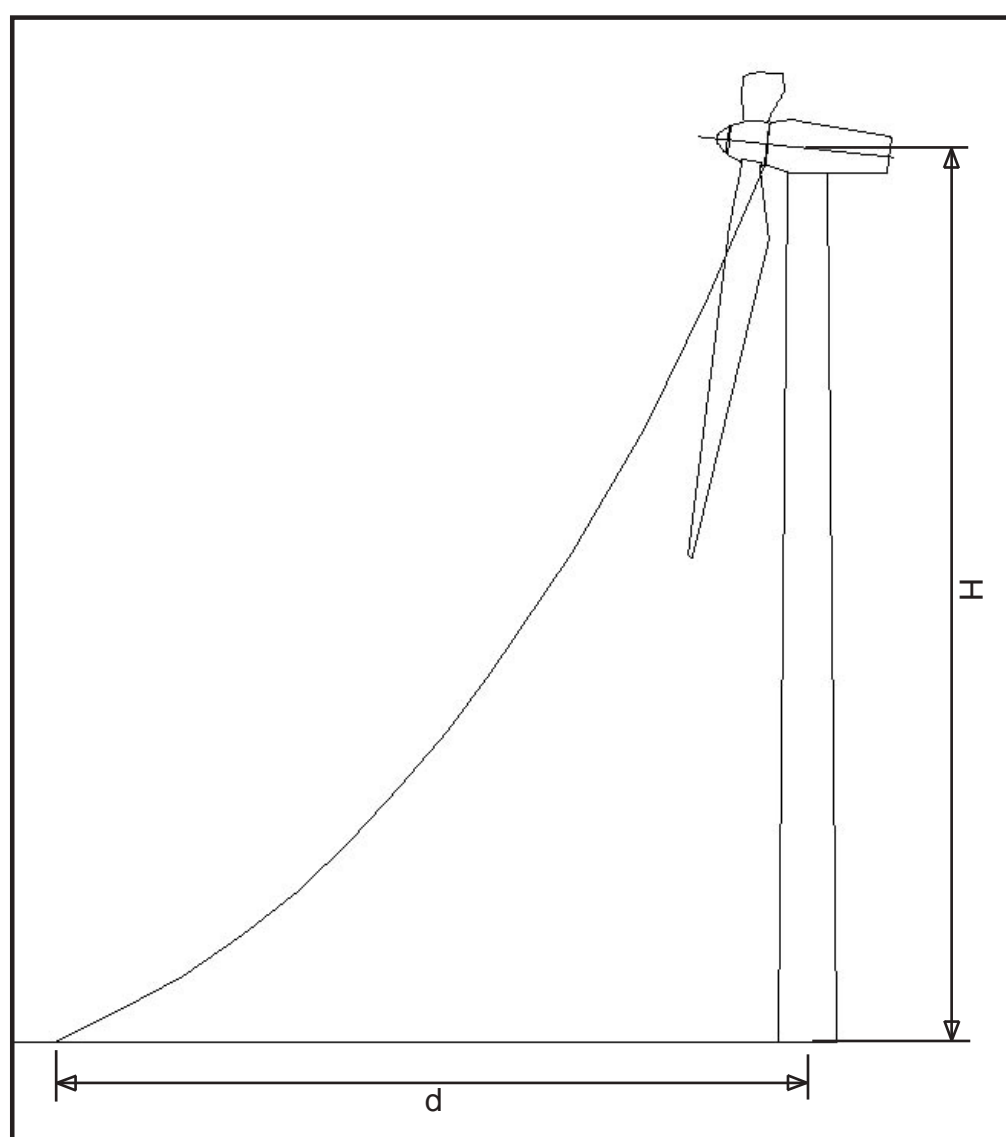

$$d \geq H$$

Wire rope tightened by traction device fixed to vehicle.



**DANGER**

<p><b>Risk of wounds and injuries due to fall of objects, fall from different level and / or breaks.</b></p>	<p>Danger of death due to fall of objects, fall from different level and / or breaks. Danger for movements out of control.</p>
<p><b>Risk of overtension in the main guide wire rope.</b></p>	<ul style="list-style-type: none"> <li>-Control the pre-tension of the main guide wire rope with dynamometer or see images at section 8.3.1.</li> <li>-The vehicle must be correctly parked with his emergency brake and an adequated gear.</li> <li>-The car's keys must be controlled by the responsible and must be out of the car in order to avoid his movement.</li> <li>-It's mandatory to lock the car with the main guide wire rope by standardized for consignment. (See the examples on the following page).</li> <li>-It's forbidden to move the car if the main guide wire rope is fixed.</li> <li>-The car and the traction device of the main guide wire rope must be always controlled by the responsible.</li> </ul>



Examples of standard elements for locking a car: Steering wheel locking and pedal locking system.



The suspension wire rope gets tight with a traction device Fixator m.lift400 type, Yaletrac Y08 type or similars. The device is fixed to the car.

Fix the device with textile slings with an adequated resistance. Is advisable to install a dynamometer in order to control the pre-tension, which must be 25kg. The maximum load on the guide wire rope is 125kg.

Follow the instructions of the manufacturer, seep the main guide wire rope into the traction device and tighten the wire rope (see images at section 8.3.1.).

For regulate the platform's position see section 8.3.2 of this manual.

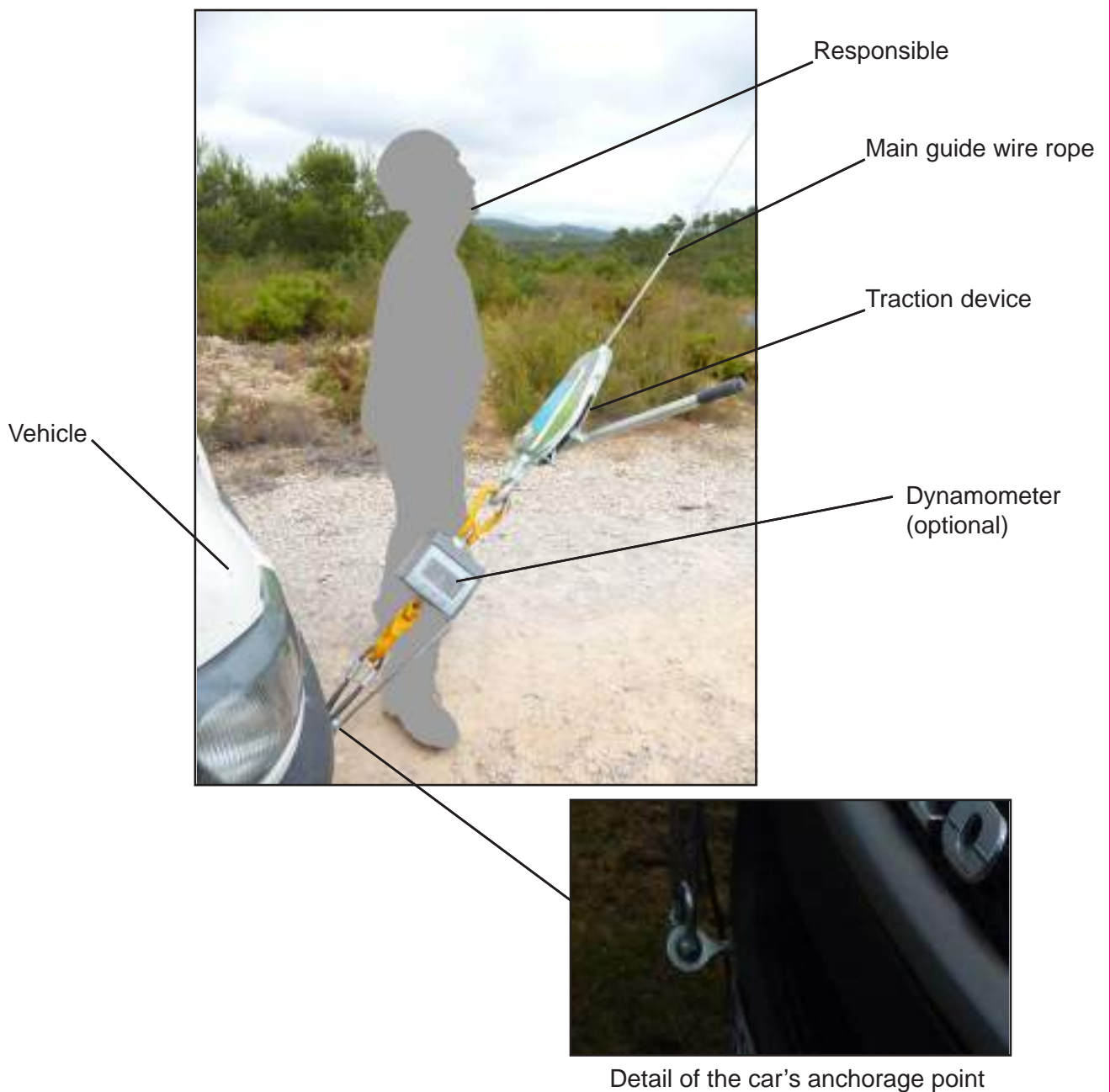

8.3.2-Guide regulation from the platform, secondary guide wire rope.

By means of the secondary guide wire rope controlled from the platform with the manual winch.  
Utilization:

1-Mount the pulleys (1) to the main guide wire rope with the platform at the ground.

2-Release the wire rope of the traction device of the platform (2) and anchor it to the trolley (1).

3-By means of the traction device (2) and from the platform adjust the distance between the platform and the main guide wire rope until place the platform at the work area.



**DANGER**

<p><b>Risk of wounds and injuries due to fall of objects, fall from different level and / or breaks.</b></p>	<p>Danger of death due to fall of objects, fall from different level and / or breaks.</p>
<p><b>Risk of overtension in the main guide wire rope.</b></p>	<p><b><u>-The angle between the suspension wire rope and the horizontal must be between 76° and 90°.</u></b> This angle is checked periodically, before and after each vertical movement and / or regulation of the guidance, following the procedure described in section 8.3.2.1.</p>



1-Trolley for link main and secondary guide wire ropes



2-Traction device with special lever of 500mm in length

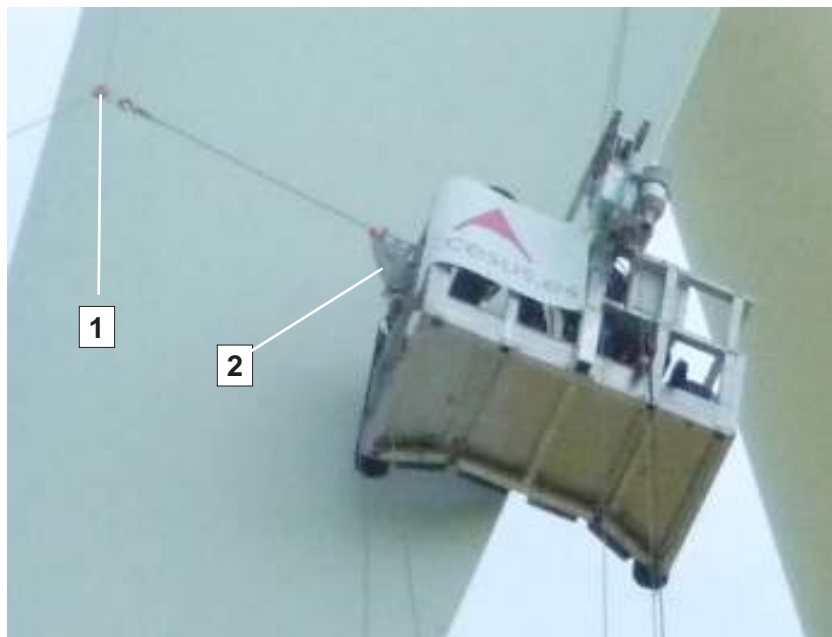

8.3.2.1- Checking the wire rope inclination



**DANGER**

**Risk of wounds and injuries due to fall of objects, fall from different level and / or breaks.**

Danger of death due to fall of objects, fall from different level and / or breaks.

**Risk of overtension in the main guide wire rope.**

**-The angle between the suspension wire rope and the horizontal must be between 76° and 90°.** This angle is checked periodically, before and after each vertical movement and / or regulation of the guidance, following the procedure described bellow

-The angle of the work or safety wire rope with respect to the horizontal, **SHOULD NEVER BE LESS THAN 76°.**

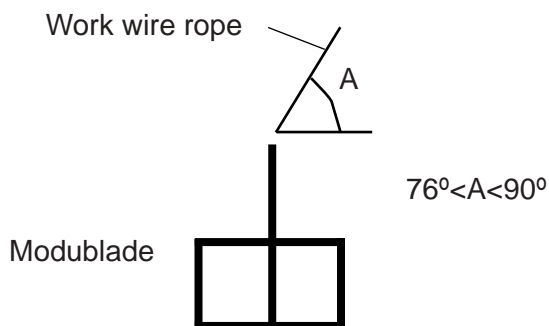

To carry out the verification of the inclination (A) of the cable of the platform modublade has a tool and digital inclinometer that allows the verification of the inclination of the wire rope in a comfortable and safe way.

Slit is a tool to which the magnetized digital inclinometer is attached. Through this system we will check the inclination (A) of the work or safety wire rope.



The measurement of the angle (A) is made by positioning the grooves of the tool on the work or safety wire rope according to the following images.

Turn on the digital inclinometer, pressing ON / OFF. Make sure that the angle measurement is absolute, in the upper right part of the screen you should indicate ABS. Otherwise, press ON / OFF until the ABS indication is active.



Before starting the work, carry out an angle measurement check with the platform suspended 1m high. The reading of the inclinometer screen must be 90° or very close. See next image.



The angle (A) that the inclinometer must indicate must be in a range between 76° and 90°.

When the inclinometer reading is 80° we must carry out continuous checks.

If the angle (A) reaches 76° we must relax the secondary guide wire and make sure that the angle is between 76° and 90°.

The angle of the work or safety wire rope with respect to the horizontal, **SHOULD NEVER BE LESS THAN 76°**.



### 8.3.3-Blade's embracing (optional).

The textile tape installed at the manual winch allows to embrace for positioning the platform. Also facilitates the platform's guide at the highest places where the guide wire rope is not enough.

Utilization:

- 1-Release enough tape in order to embrace the blade.
- 2-Manually embrace the tape behind the blade until anchor the tape at the other side of the platform.
- 3-By means of the manual winch, and from the platform, regulate the tape's tension for positionate the platform.
- 4-Before elevate the platform with the e.lift hoist release the tape's tension a little in order to avoid the overload.

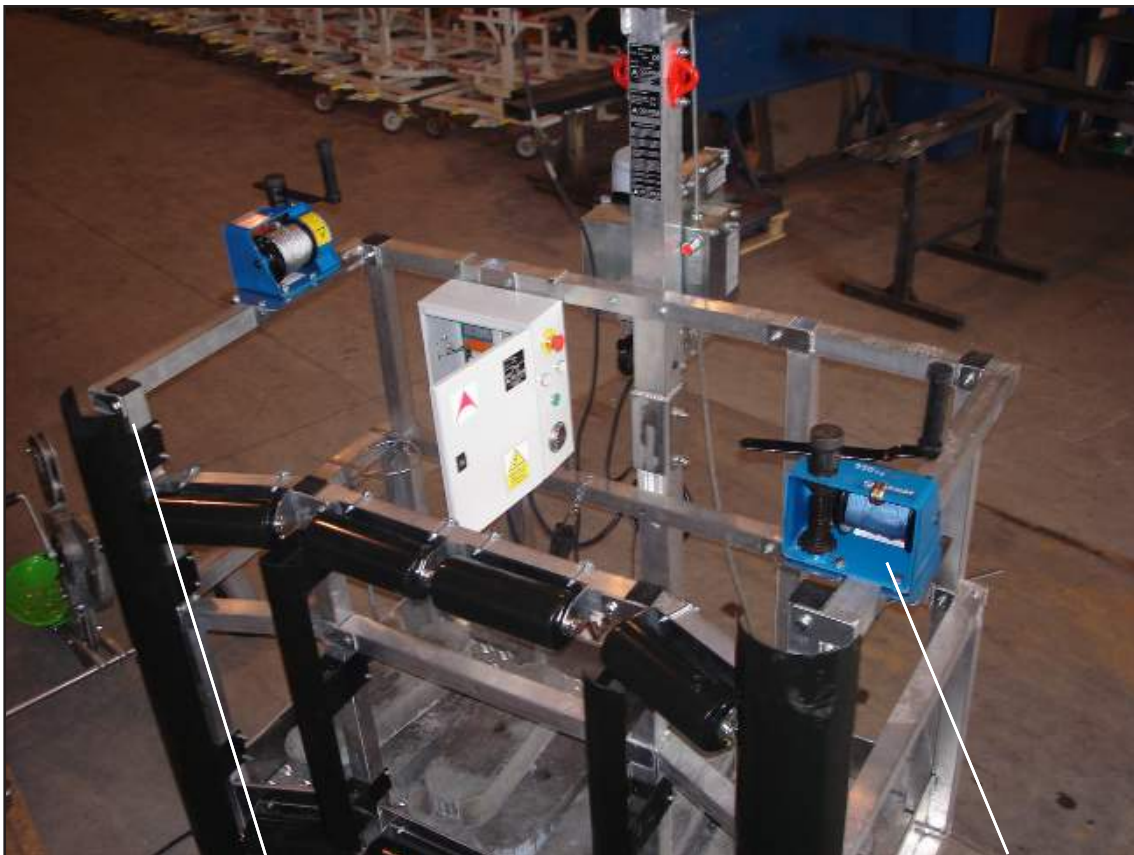

Tape's anchorage

Tape for blade's embracing



Tape's anchorage detail

### 8.3.4- Placing of the nacelle and blade

#### 8.3.4.1-Placing of the nacelle and blade depending on the blade area to repair:

This document describes how to place the nacelle and blade to operate with blade maintenance platform Accesus Modublade.

It is very important to know beforehand where the area to be repaired is, its size and the method of repairing.

It is necessary to pre-plan which movements and from which area to which area we will have to move the platform. The succes of the repair depends on it.

Once known the positions in where should remains the platform, we will know the surface of the blade which must be accessed.

Depending on that will be defined three aspects:

- a) Position of the suspension system. (from which is suspended)
- b) Degrees of pitch of the blade.
- c) Position of the nacelle relative to the cable guide.

The following briefly describes the blade and its most notable parts. Then it is defined how to place the suspension system, the blade and nacelle depending on the area to be repaired.

#### 8.3.4.1.1-Description of the blade:

- 1 Root
- 2 Edge of attack BA
- 3 Tip
- 4 Edge exit BS

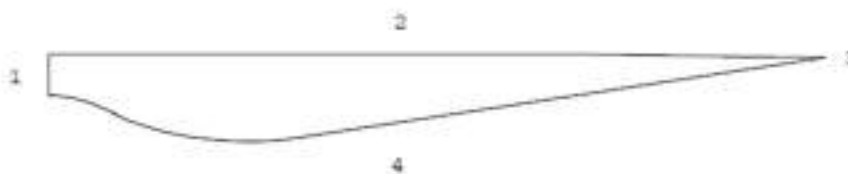

Blade section:

- 1 Edge of attack BA
- 2 Upper shell CS
- 3 Edge of exit BS
- 4 Lower shell CI

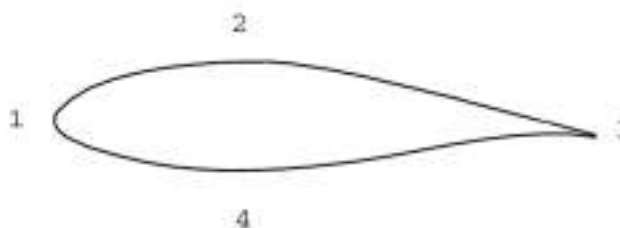

#### 8.3.4.1.2-Placement of the rotor:

Block the rotor with the blade to repair at 6 o'clock.

## 8.3.4.1.3-Degrees of pitch of the blade:

You can block the blade at 0 ° 30 ° 60 ° and 90 ° (degrees rounded for convenience).

Blade image (top view) in different blocks:

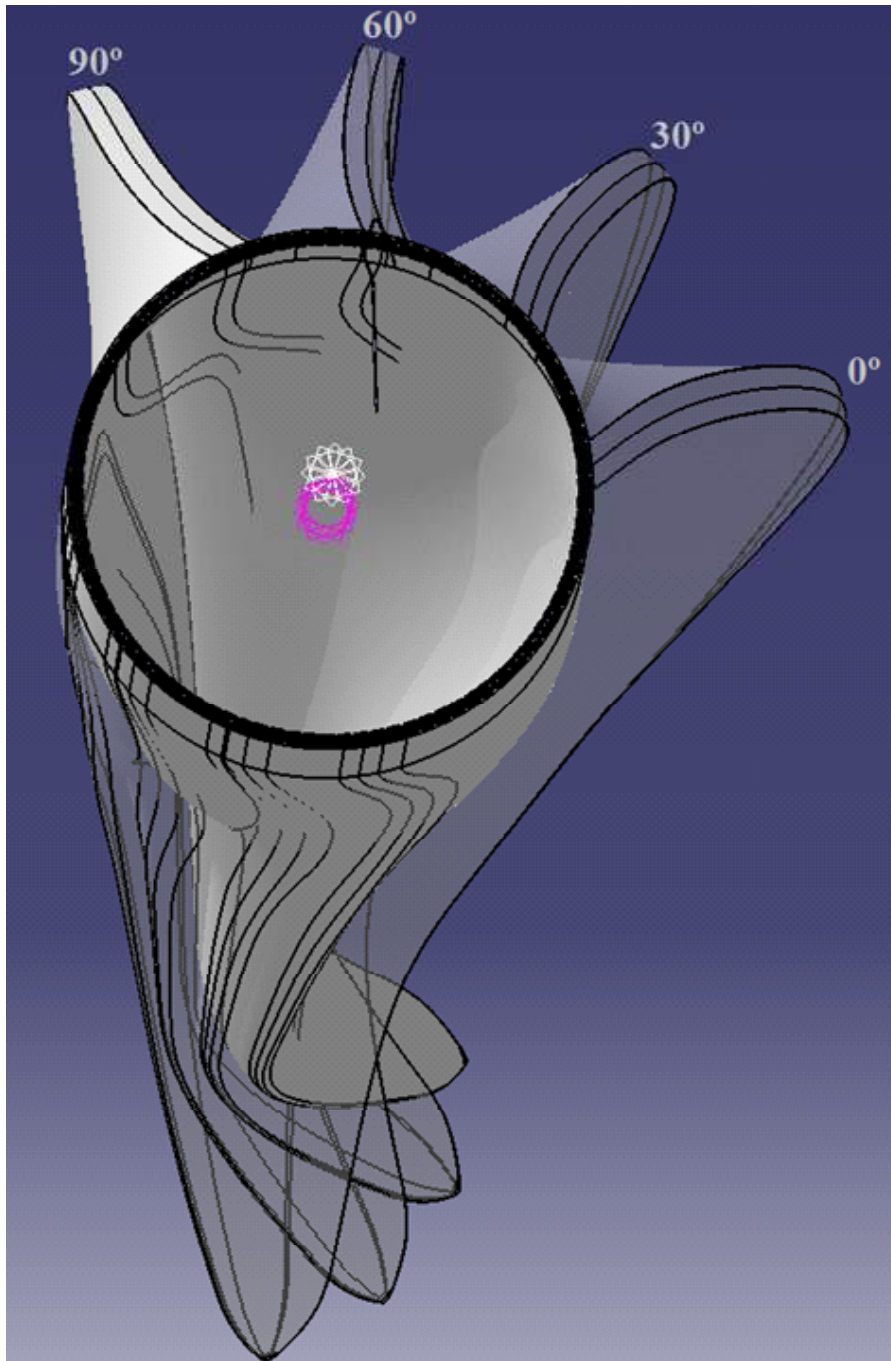



8.3.4.2-Access to upper shell:

If the repair is to be performed on the **upper shell**, the **suspension system** of the platform has to be placed on the **left blade** (facing the rotor from the front and from outside the nacelle).



Access to different parts of the upper shell depends on the degree of pitch of the blade. Prior to lifting it has to be planned the area to be accessed.

The following images show the access to areas of the upper shell in different positions of pitch. Green areas are accessible and the area in red is not possible. To access the area marked in red the platform has to be suspended from the right blade.

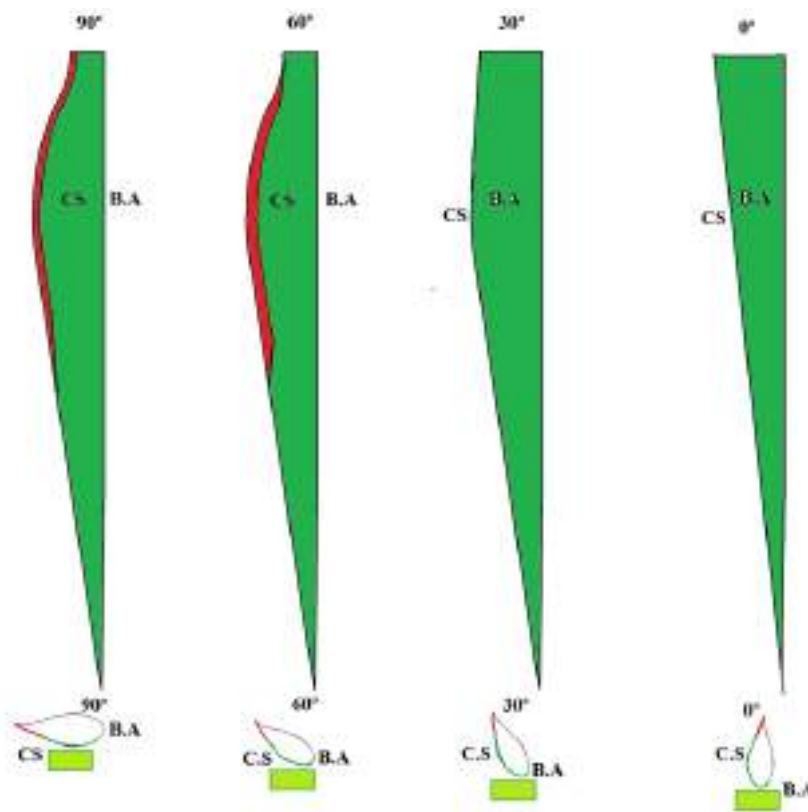

#### 8.3.4.2.1-Orientation of the platform for access to upper shell:

To ensure correct positioning and close to the surface to be repaired, guide the nacelle to achieve align the guide wire as close as possible to the surface to work.

The wire guide exits from the upper front roof hatch of the nacelle and it is anchored to a vehicle or counterweight at a defined distance. (green guide cable).



From the anchor point and facing the nacelle, the nacelle has to be aligned so that the guide wire keeps as close as possible to the surface to work.

For example, if you are going to work on the root, the guide wire will be more to the left. On the contrary, if you are going to work on the tip, the guide wire must be more to the right. It should guide the nacelle to get a correct position of the cable.

**NOTE: It is very important to place the wire guide well, so that when ascending the platform it is not fit for the tip and rests on the lower shell.**

### 8.3.4.3-Access to lower shell:

If the repair is to be performed on the **lower shell**, the **suspension system** of the platform has to be placed on the **right blade** (facing the rotor from the front and from outside the nacelle).

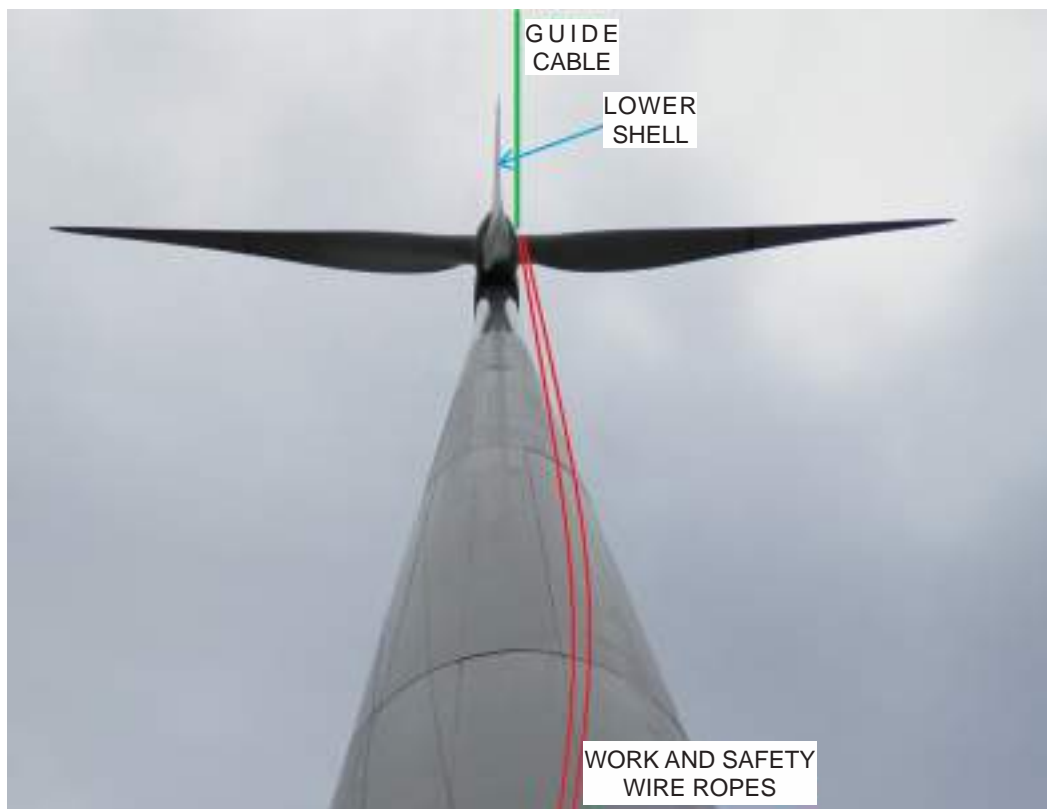

Access to different parts of the lower shell depends on the degree of pitch of the blade. Prior to lifting it has to be planned the area to be accessed.

The following images show the access to areas of the lower shell in different positions of pitch.

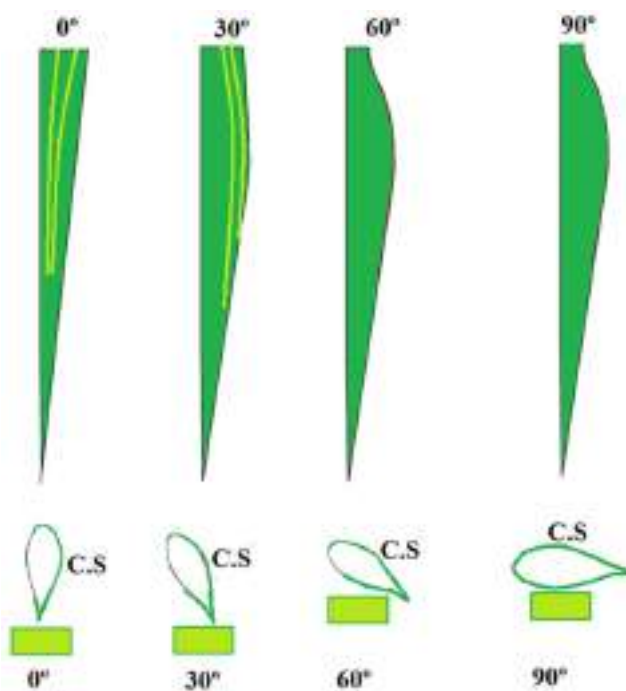

### 8.3.4.3.1-Orientation of the platform for access to lower shell:

To ensure correct positioning and close to the surface to be repaired, guide the nacelle to achieve align the guide wire as close as possible to the surface to work.

The wire guide exits from the upper front roof hatch of the nacelle and it is anchored to a vehicle or counterweight at a defined distance. (green guide cable).



From the anchor point and facing the nacelle, the nacelle has to be aligned so that the guide wire keeps as close as possible to the surface to work.

For example, if you are going to work on the root, the guide wire will be more to the right. On the contrary, if you are going to work on the tip, the guide wire must be more to the left. It should guide the nacelle to get a correct position of the wire rope.

**NOTE: It is very important to place the wire guide well, so that when ascending the platform it is not fit for the tip and rests on the lower shell.**

## 8.4-Use of the platform to work on towers

For platforms working at heights greater than 40 m and in areas exposed to wind, lateral movements of the platform must be limited by means of a suitable retention system

### 8.4.1-Tower embrace

Embrace the tower using ropes or tapes. See images at the bottom of the page.

### 8.4.2-Horizontal displacement of the platform

Maintenance of wind turbine towers usually requires surrounding the tower at the level of joining between two sectors. These joints are at different heights and are horizontal.

The way of accessing these joints with the suspended platform Modublade is by turning the nacelle from where the platform is suspended.

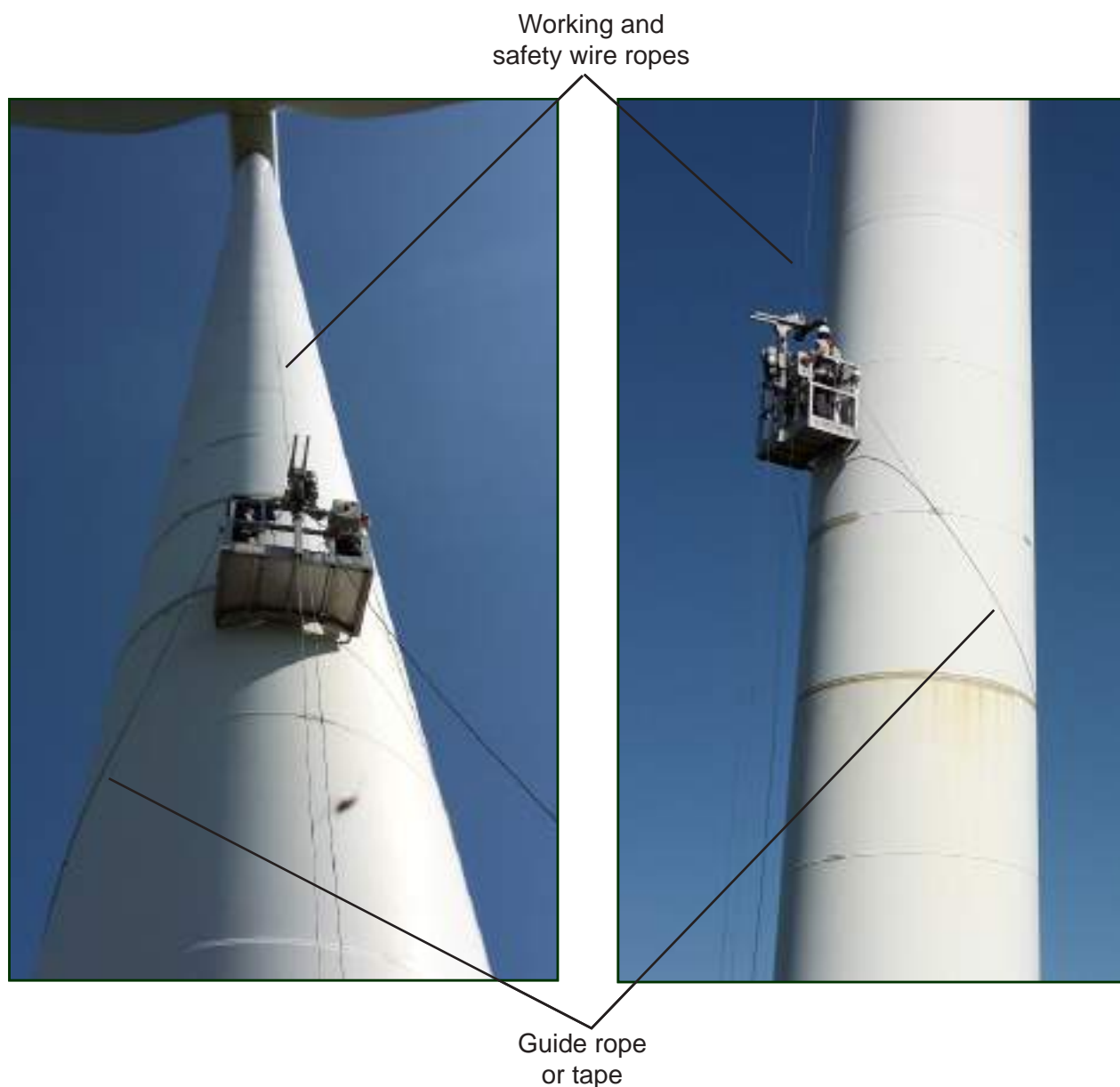

**8.4.2.1-Technical information for horizontal displacement:**

Para realizar el giro de la nacelle con la máxima seguridad, se deben cumplir las siguientes condiciones:

Nacelle turning maximum speed:	1º/s
Tower maximum diameter:	10 m
Maximum turning speed at maximum diameter:	~1,3 m/s
Tower maerial	Steel / concrete
Tower maximum height	150 m

**8.4.2.2-Safety instructions:**

This safety instructions must be followed for the operation of turning the nacelle with the Modublade suspended platform suspended at height, from here “the operation”.

- The operation and safety must be managed and controlled by the team leader.
- The turning of the nacelle must be controlled manually by a “dead man” control system that avoids the turning in case the man in controlling it gets unconscious or incapacitated. The turning can not be automatic or programmed.
- Every people involved in the operation must have a continuous and reliable means of communications (walkie or similar). Above all between people on the platform and people controlling the nacelle’s turning.
- People involved in the operation must be equipped, at least, with the following PPE:
  - Safety gloves,
  - Safety boots,
  - Safety helmet,
- People on the platform must be equipped, at least with:
  - Safety gloves,
  - Safety boots,
  - Safety helmet,
  - Harness, clamped to:
    - 1,5m sling with shock absorber, clamped to EN795 points on Modublade suspended platform,
  - Emergency descender with its rope lenght enough for tower height, 1 per platform.
- The modublade suspended platform must be guided all time, but for the operation the guiding rope or tape should be loose a little to make the movement easier.
- During the operation one of the workers must check that the wire rope on the floor does not hook with anything on the bottom of the tower, for example with the structure of the stairs. If this happens the operation must be stopped immediately.

### 8.5-Electric controls.

Up and down platform movements are controlled from the electric cabinet placed in the middle of the platform.

In case of an error, wait until that movement finish completely before efectuate other order. The buttons has an inmediate action.

**Avoid maneuvers with consecutives impulses at the control.**

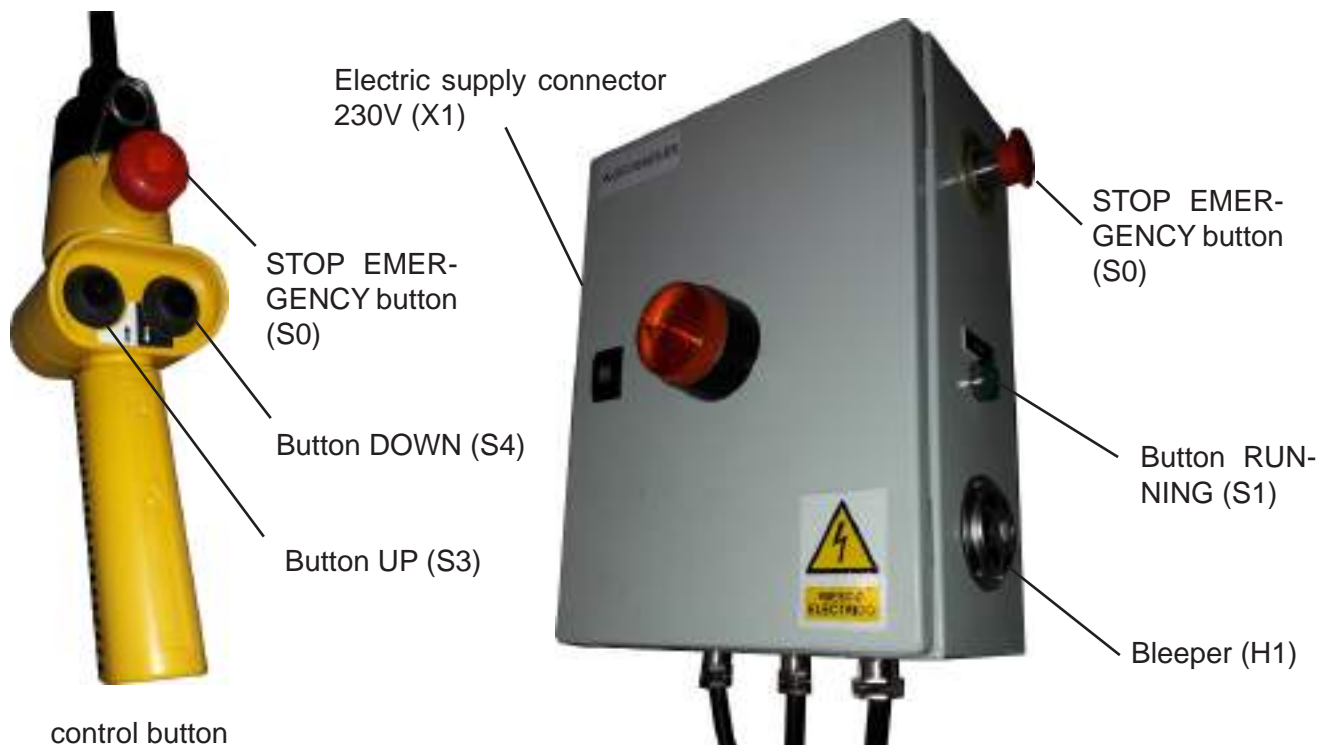

### 8.6-No power emergency descent.

**It's forbidden to descend the platform using the e.lift hoist brake when the electric descent is possible.**

The powered hoists are equipped with a manual descent system in case of no power supply. It can be used only in case of emergency.

- a) Stop the power supply disconnecting the socket.
- b) Raise the emergency down lever ubicated at the rear side of the hoist in order to open the brake service. The platform descends by his dead weight and his velocity is limited and controlled automatically.
- c) If the platform don't descend, an initial impulse must be given turning clockwise the maneuver's flywheel (1) situated in the axis of the engine after the extraction of the plastic cap (2).
- d) The platform stops when the brake's handle is released.
- e) When the platform is on the ground, remove the flywheel and place it into the slot. Place the plastic cap over the engine.



### 8.7-Action in case of fall arrest locking.

**In case of securichute fall arrest blockade:**

**If there is power supply.**

Press “UP” at the electric cabinet until the suspension wire rope get tight. Open the Reset lever of the securichute fall arrest device. Now you can continue working.

**If there aren't power supply.**

Extract the plastic cap (2). Turn clockwise the maneuver flywheel (1) placed in the engine's axis and, at the same time, open the engine's brake by raising the lever until the suspension wire rope gets tight. Open the reset lever of the securichute fall arrest device. Now you can continue working.

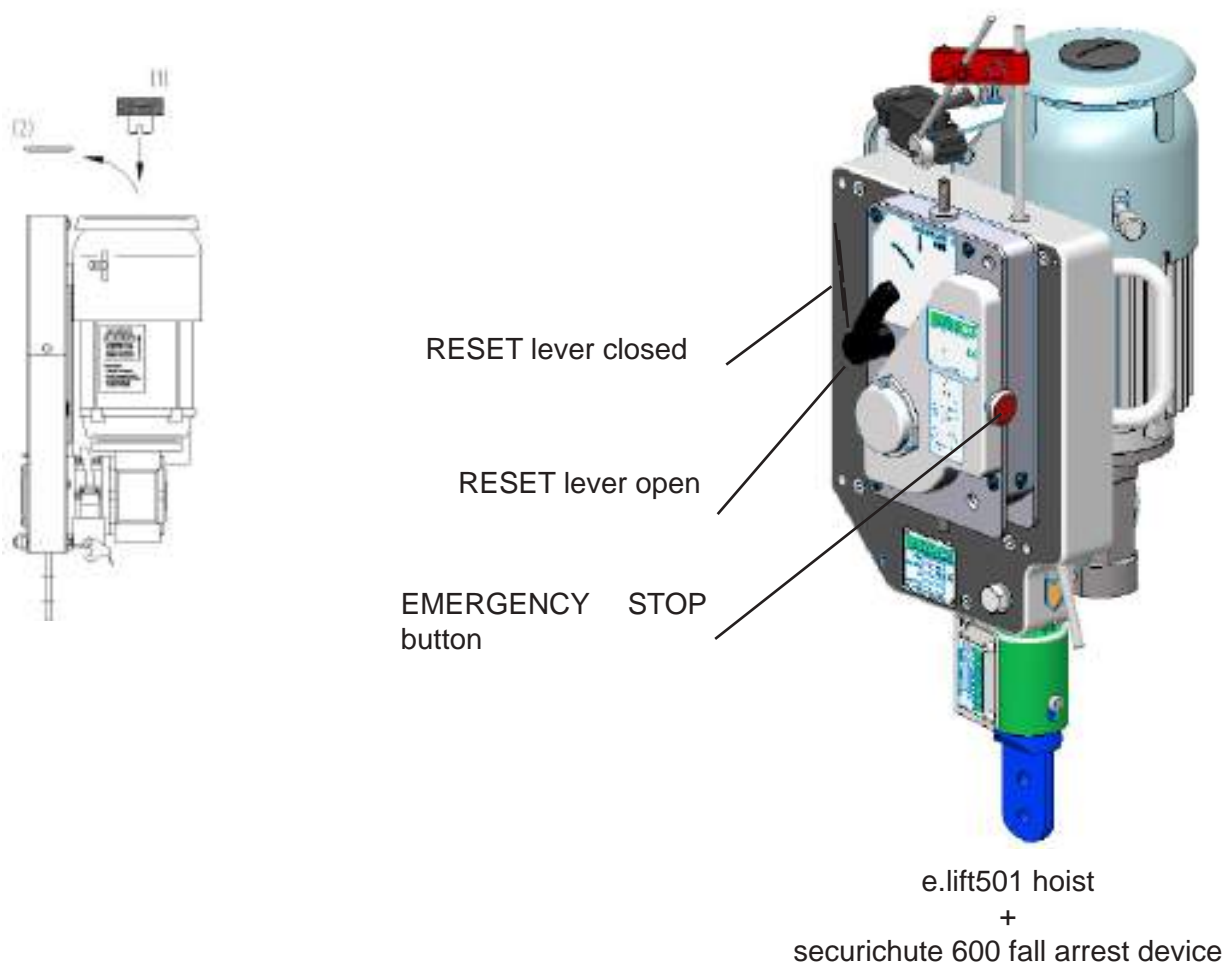

### 8.8-Request for help with the acoustic bleeper.

**In case of emergency or request for help.**

The ACOUSTIC bleeper (H1) placed in the electric cabinet can be used as an S.O.S. distress signal or to advert other workers. This sign is activated with the EMERGENCY STOP button (SO) blocked and pushing START (S1) button.

**S.O.S. is the most used distress signal. Consists of a continuous sequence of three-dits/three-dahs/three-dits, all run together without letter spacing.**



8.9-Platform's evacuation.



**DANGER**

**Risk of wounds and injuries due to fall of objects, fall from different level and / or breaks.**

Danger of death due to fall of objects, fall from different level and / or breaks.

-The worker must have formation for use the emergency descender.

**-The descender must be equipped with a rope sufficiently long to be able to descend to the ground or safe area.**

-Use intercomunicators in order to coordinate maneuvers between the workers at the base of the tower and the workers at the suspended platform.

-Ensure that nobody is at the area capable of objects fall.

Before an emergency evacuation it's necessary to exhaust all the possibilities described at section 8.5, section 8.6, section 8.7 and section 8.8.

Use the descender only if is not possible to descend by means of the platform and if exists an imminent danger.

Anchor the descender to the anchorage point. Spread the rope until the ground. Proceed to the rescue following the instructions described at the descender's manual.

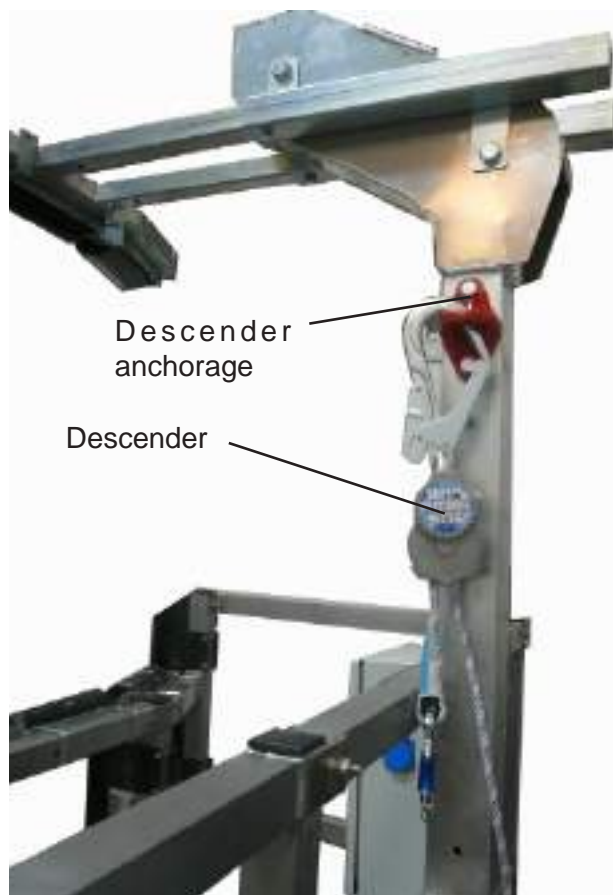

### 8.10-Removing the wire ropes.



**DANGER**

<p><b>Hurts for wire ropes manipulation.</b></p> <p><b>Risk of wounds and injuries due to fall of objects, fall from different level and / or breaks.</b></p>	<p>Danger of cuts and scratches.</p> <p>Danger of death due to fall of objects, fall from different level and / or breaks.</p>
	<p>-Before to remove the wire ropes and during the maneuver, ensure that nobody is on the danger's area.</p> <p>-Use adequate PPE's: harness, protection gloves, safety boots, helmet, etc.</p> <p>-Avoid the creation of loops when manipulating the wire ropes.</p> <p>-Use intercomunicators in order to coordinate the maneuvers between the workers at base of the tower and the workers at the nacelle.</p>

In general, at least two operators are needed for the disassembly of the cables: one on the platform and the second at the level of the suspension. The latter must be equipped with a harness that is anchored to a sufficiently strong anchor point.

- a) Get down the platform until the ground and loose the wire ropes.
- b) Extract the suspension wire rope from the hoist pressing the “descend” button, or manually.
- c) Extract the safety wire rope from the fall arrest device.
- d) The operator on the nacelle disengages, one by one, work wire rope and safety wire rope, and with a rope of appropriate length leaving them down to the ground. Do not drop the wire ropes in free fall.
- e) At the level of the platform roll correctly the suspension wire rope and the safety wire rope into their winders

## 8.11-Dismantling the platform.

**DANGER**

<b>Risk of wounds and injuries due to fall of objects, fall from different level and / or breaks.</b>	Danger of cuts and scratches.
	Danger of death due to fall of objects, fall from different level and / or breaks.  -Use adequate PPE's: harness, protection gloves, safety boots, helmet, etc.  -Keep order.

For dismantle the platform are necessary 2 people. The unmounting depends on the way for transport the platform.

To unmount the platform follow inversely the steps described at section 6.4.

### 8.12-Transport of the plataform



#### IMPORTANT

**Risk of wounds and injuries due to fall of objects, breaks.**

Damage to machines or the environment

- Use adequated PPE's: harness, protection gloves, safety boots, helmet, etc.
- Keep order.
- Remove the motor from the stirrup.

Modublade suspended platform can be transported and stored totally mounted, partially mounted or totally dismantled. In any case, the motor must always be disassembled from the basket for risk of breakage.



Weight: 100 kg



Weight: 137 kg

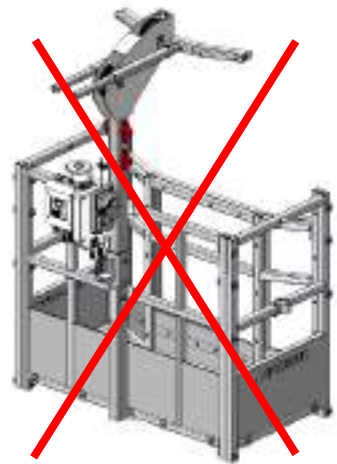

For long distance transport or long time storage, the platform can be stored in 2 european pallets: 1 for the platform and 1 for the hoist and the wire ropes.



## 9-Residual risks not covered by the design of the platform.

- The platform is not equipped with an anti-collision device which stops automatically the ascent or descent in case of obstacle.

The worker must verify visually if there are any obstacles in the trajectory.



**DANGER**

- SECURICHUTE fall arrest device is not equipped with a device which stops automatically the ascent or descent in case of block.

The worker must verify visually if the SECURICHUTE gets blocked and realize the maneuvers described to unblock.

If the SECURICHUTE is blocked the platform can ascend normally but can not descend. If this case is given see the section 8.7 described in this manual.

- The noise level generated by the e.lift® powered hoist has a maximum of 65dB (A) from a distance of 1m.

- The platform is not equipped with a device for control the ubication of the wind turbine's blade which stops automatically the descend in case of arrive at the blade's point.

The worker must verify visually the position of the platform and realize the necessary maneuvers for a safety exit from the blade to the tower by means of the guide wire rope.

- Don't work with wind superior to 50 km/h (14 m/sec).

- It's forbidden to work in case of strong wind or storm.

## 10-Troubleshooting



**DANGER**

<b>Risk of wounds injuries or death due to fall of objects, fall from different level, breaks and/or electric contact.</b>	Danger of death due to fall of objects, fall from different level and / or breaks. Danger of death by electric contact.
	-Stop the works immediately. -Identify the cause and solution the breakdown. -Before the works disconnect the power supply plug (CEE) of the platform. The worker must verify in every moment that the plug is disconnected.

These are the instructions to identify and repair the breakdowns.

<b>Faults observed</b>	<b>Potential causes of the fault</b>	<b>Remedies</b>
The motor does not rotate	<ul style="list-style-type: none"> <li>-The brake without power is disconnected or out of order</li> <li>-The temperature sensor is activated</li> <li>-The overload is activated</li> <li>-The motor has a mechanical fault</li> <li>-The contactor in the hoist is out of order or disconnected</li> <li>-The general contactor of the control box is out of order or disconnected</li>   <li>-The limit switch is activated</li>   <li>-Fault in the control circuit</li> <li>-Fault in the power circuit</li> <li>-Power supply fault</li> <li>-Humidity “jams” the brake on the motor.</li> </ul>	<ul style="list-style-type: none"> <li>-Reconnect the brake or change it</li>   <li>-Wait for a drop in temperature</li> <li>-Reduce the load</li> <li>-Check the motor</li> <li>-Reconnect or replace it</li>   <li>-Reconnect or replace it</li> <li>-Have a competent person check it</li>   <li>-Check</li>   <li>-Have a competent person check it</li> <li>-”Tap” gently on the motor spindle while pressing on the control buttons.</li> </ul>
The hoist does not rise	<ul style="list-style-type: none"> <li>-The grooved pulley is worn or dirty</li> <li>-The starting condenser and the centrifugal coupler are disconnected or out of order (only for a single phase hoist)</li> <li>-The temperature sensor is activated</li> <li>-The overload is activated</li> <li>-The motor is blocked</li> <li>-The contactor on the hoist is out of order or disconnected</li> <li>-The limit switch is activated</li> <li>-Fault in the control circuit</li> <li>-Fault in the power circuit</li> </ul>	<ul style="list-style-type: none"> <li>-Verification</li> <li>-Verification</li>   <li>-Wait for a drop in temperature</li> <li>-Reduce the load</li> <li>-Check</li> <li>-Verification (maintenance)</li> <li>-Reconnect or replace it</li>   <li>-Have a competent person check it</li> </ul>
The hoist does not descend	<ul style="list-style-type: none"> <li>-The fall-prevention system is engaged</li> <li>-The temperature sensor is activated</li> <li>-The overload is activated</li> <li>-The lack of load is activated (optional)</li>   <li>-The motor is blocked</li> <li>-The contactor in the hoist is out of order or disconnected</li> <li>-Fault in the control circuit</li> <li>-Fault in the power circuit</li> </ul>	<ul style="list-style-type: none"> <li>-Verification</li> <li>-Wait for a drop in temperature</li> <li>-Reduce the load</li> <li>-Check then press “OK/shunt”</li>   <li>-Check the motor</li> <li>-Reconnect or replace it</li>   <li>-Have a competent person check it</li> </ul>

The motor is powered but stalls (chugging)	<ul style="list-style-type: none"> <li>-The brake without power is disconnected or out of order</li> <li>-The starting condenser and the centrifugal coupler are disconnected or out of order (only for a single phase hoist)</li> <li>-The motor is blocked</li> <li>-Fault or one phase missing in the power circuit</li> <li>-Supply lead section too small</li> </ul>	<ul style="list-style-type: none"> <li>-Reconnect the brake or change it</li> <li>-Verification</li> <li>-Verification (maintenance)</li> <li>-Check the power supply</li> <li>-Replace the power cable</li> </ul>
The hoist does not lift the load	<ul style="list-style-type: none"> <li>-The grooved pulley is worn or dirty</li> <li>-The permanent condenser is out of order</li> <li>-The starting condenser and the centrifugal coupler are disconnected or out of order (only for a single phase hoist)</li> <li>-The temperature sensor is activated</li> <li>-The overload is activated</li> <li>-Fault or one phase missing in the power circuit</li> <li>-Supply lead section too small</li> </ul>	<ul style="list-style-type: none"> <li>-Verification</li> <li>-Verification</li> <li>-Verification</li> <li>-Wait for a drop in temperature</li> <li>-Reduce the load</li> <li>-Check the power supply</li> <li>-Replace the supply lead</li> </ul>
Current too high	<ul style="list-style-type: none"> <li>-The brake without power is disconnected or out of order</li> <li>-The permanent condenser is disconnected or out of order</li> <li>-The motor is blocked</li> </ul>	<ul style="list-style-type: none"> <li>-Reconnect the brake or change it</li> <li>-Reconnect the condenser or change it</li> <li>-Verifications (maintenance)</li> </ul>
Slow sliding	<ul style="list-style-type: none"> <li>-The grooved pulley is worn or dirty</li> <li>-The brake without power is worn</li> <li>-The adherence system is worn or dirty</li> </ul>	<ul style="list-style-type: none"> <li>-Verification</li> <li>-Replace the brake</li> <li>-Verification</li> </ul>
Uncontrolled manual descent	<ul style="list-style-type: none"> <li>-The manual lowering condenser is worn</li> </ul>	<ul style="list-style-type: none"> <li>-Replace the condenser</li> <li>-Check the contactor in K1 and K2</li> </ul>
Manual descent not possible	<ul style="list-style-type: none"> <li>-The brake without power is jammed</li> <li>-The fall-prevention system is jammed</li> <li>-The load below the hoist is too little to initiate the movement</li> </ul>	<ul style="list-style-type: none"> <li>-Verification</li> <li>-Use the hand wheel (item 3)</li> </ul>

## 11-Maintenance.



### DANGER

<b>Risk of wounds injuries or death due to fall of objects, fall from different level, breaks and/or electric contact.</b>	Danger of death due to fall of objects, fall from different level and / or breaks. Danger of death by electric contact.
	-Identify the cause and solution the breakdown. -Before the works disconnect the power supply plug (CEE) of the platform. The worker must verify in every moment that the plug is disconnected.

Take into account the maintenance work and intervals described below:

Interval	Work	Execution
Daily	-Check lift attachment. -Check the SECURICHUTE fall arrester, see section 11.3. -Check for dirt on the wire rope. -Running test, see section 6.5 -Check the operation of the traction device, see section 11.4.	User
Weekly	-Check wire rope, see section 11.1.1. -Check connection hose and control hose	User
1 time per year	-Check of complete security of the equipment	Accesus or a workshop authorized by Accesus
when necessary	-Clean, lubricate and / or replace the wire rope, see section 11.1 and 8.10. -Clean the lift, see section 11.2. -Clean the limit switches, lubricate the limit switch drive -Lubricate the traction device.	A person named and formed by the operator



## 11.1-Wire ropes

Only the wire ropes recommended and supplied by ACCESUS guarantee the operation of the lift.  
 Cleaning: If necessary, brush dry, dirty wire ropes and, if necessary, grease them again.  
**NEVER CLEAN WIRE ROPES WITH HIGH PRESSURE WATER!**

Greased: Lifting wire ropes should be greased regularly. To do this use IGP SHP 50 grease or equivalent and distribute it by means of a cloth along the length of the wire rope.

**NEVER LUBRICATE THE CABLE WITH LUBRICANTS CONTAINING BISULPHITES (eg Molycote).**

### 11.1.1-Replacing the wire ropes.

Only wire ropes recommended and supplied by ACCESUS guarantees the start up of the hoists safely.

The wire rope has a nominal pipe size of 8,3mm, a hook with a safety clip in one end and a rounded tip at the other side. The wire rope has a nameplate which identifies the origin, diameter and length.

The wire rope must be replaced in this cases:

a) Reduction of the diameter. Minimum diameter 7,4 mm (for a wire rope with a nominal pipe size of 8,3 mm).

b) Breaking of more than 10 threads over a length of 25 cm for a wire rope of Ø8,3 mm.

c) Deformity or breaking of his clamps.

d) Wire rope crushed or stripped.

e) Hard oxidation.

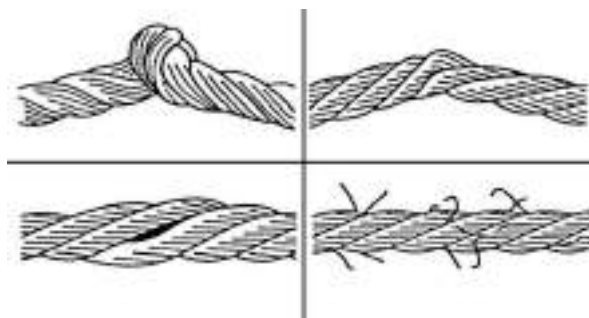
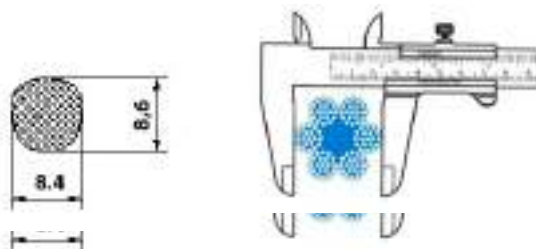

## 11.2-Elevator

No maintenance is required on the engine, gear or brake until it reaches the annual review interval.

-In case of dirt, clean from the outside.

-Keep brake free of oil and grease.

### 11.3-Securichute fall arrest device

Control regularly the correct start up of the fall arrest devices.

If the fall arrest device doesn't works correctly it must be replaced and repaired immediately by ACCESUS or by an authorized repairer.

1- Diary verification:

Verify that the Securichute holds correctly the secondary wire rope.

- Press the Emergency Stop button.

The clamps must closes automatically and be impossible to take out the wire rope manually.

- Reset the Securichute pressing the Reset Handle. The secondary wire rope must flows freely inside the Securichute fall arrest device.

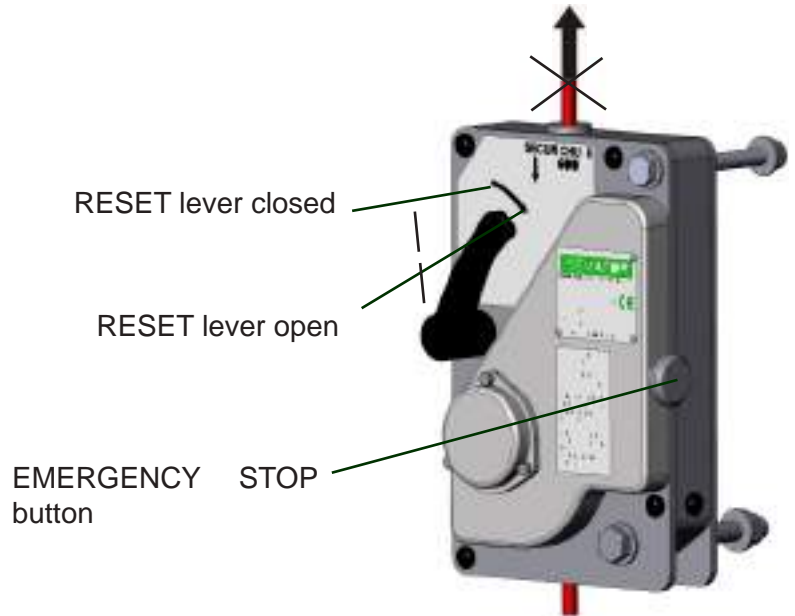

2-Periodic verification (weekly).

With the platform on the ground:

- Pull up, with a strong and quick blow, the secondary wire rope.

The fall arrest device must subject immediately the secondary wire rope. Repeat this operation at least 3 consecutive times.

- Reset the Securichute fall arrest device by pressing his reset handle.

### 11.4-Traction device

11.4.1-Inspection before initial operation

Prior to initial operation, before it is put into operation again and after substantial changes, the product including the supporting structure must be inspected by a competent person\*. The inspection mainly consists of a visual inspection and a function check. These inspections are intended to establish that the hoist is in a safe condition, has been set up appropriately and is ready for operation and that any defects or damage are detected and eliminated, as required.

\*Competent persons may be, for example, the maintenance engineers of the manufacturer or the supplier. However, the company may also assign performance of the inspection to its own appropriately trained specialist personnel.

**ATTENTION:** Always wear protection gloves for handling wire ropes.



### 11.4.2-Inspection before starting work

Before starting work, inspect the unit including the suspension, equipment and supporting structure for visual defects, e. g. deformations, superficial cracks, wear and corrosion marks. In addition also test the brake and check that the hoist and the load are correctly attached.

#### Checking the brake function:

Before starting work, always check operation of the brake: To do this, lift, pull or tension and lower or release a load over a short distance with the unit. When the hand lever is released, the load must be held in any position. This check is intended to ensure that even at temperatures below 0°C the braking mechanism is not frozen. Repeat it at least twice before starting further work

**ATTENTION:** If the brake does not function properly, the unit must be immediately taken out of service and the manufacturer must be contacted!

#### Inspection of the hoist:

Make sure the mechanical equipment is sufficiently lubricated. Each time before starting work and, if necessary, also in the course of longer work, lubricate the clamping jaw pairs with thick motor oil. Actuate the forward lever and the reversing lever several times for lubricating.

#### Inspection of the attachment point:

The attachment point for the hoist must be selected so that the supporting structure to which it is to be fitted has sufficient stability and to ensure that the expected forces can be safely absorbed. The unit must align freely also under load in order to avoid impermissible additional loading. The selection and calculation of the appropriate supporting structure are the responsibility of the operating company.

#### Inspection of the wire rope:

Check the rope for outer defects, deformations, kinks, broken individual wires or strands, crushing, swelling, rust damage (e.g. corrosion marks), strong overheating and heavy wear of the rope end connections (e.g. pressure sleeve). Rope damage may result in malfunctions and lasting damage to the cable puller. Protruding, broken wires may cause injuries. If slight damage (not yet resulting in discarding of the rope) is determined, the inspection intervals must be shortened.

#### Inspection of the top hook and load hook:

The top resp. load hooks must be checked for cracks, deformations, damage, wear and corrosion marks. The safety latch must move freely and be fully functioning.

#### Inspection of the anchor bolt:

The anchor bolt must be checked for cracks, deformations, damage, wear and corrosion marks.

#### Function check:

Before start-up, check that the rope drive is working in the unloaded condition.

**12-Spare parts.****12.1-Modublade suspended platform.**

Indicate model, serial number and description of the platform.

**12.2-E.lift powered hoist.**

Indicate model, serial number and description of the hoist.

**12.3-Electric cabinet.**

Indicate model, serial number and description of the electric cabinet. The electric scheme is inside the electric cabinet.

**12.4-Securichute fall arrest device.**

Indicate model, serial number and description of the fall arrest device.

**12.5-Traction device.**

Indicate model, serial number and description of the winch.

### 12.6-Nameplates and labels.

Check the location of the labels.

Platform nameplate (1)

ref.: 29989401

**Modelo / Model / Modèle / Modelo**  
**MODUBLADE**

---

Nº serie / serial nº /  
Nº série / Nº série     **200009-XXXXX**

---

Año / Year /  
Année / Ano     **20XX**     **CE**

Configuración / Configuration / Configuração / Configuração	1,6m	2m
Nº personas / Nº people / Nº personnes / Nº pessoas	2	2
Carga nominal plataforma / Platform Rated Load (RL) / Charge nominale de la plateforme / Carga nominal da plataforma	300kg	280kg
Peso propio / Dead weight (SWP) / Propre poids / Peso próprio	200kg	200kg
Carga máx. utilización elevador compatible / Compatible hoist Working Load Limit (WLL) / Charge max. utilisation élévateur compatible / Carga máx. uso elevador compatível	500kg	500kg

Español / English / Français / Portugues

**Fabricante / Manufacturer /  
Fabricant / Fabricante**

accessus

c/Energia 54  
08940 Cornellà de Llobregat, Barcelona-SPAIN  
Telf.: (+34) 93 475 17 73  
accessus@accessus.es     www.accessus.es

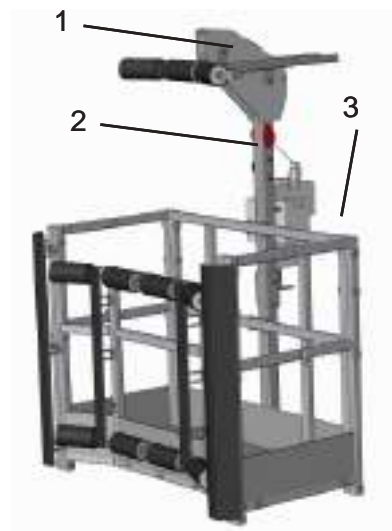

Warnings label (2)

#### WARNINGS OF USE

- This platform is destined for a professional use only. Only people with an adequate formation and suitable for works at heights are authorized.
- For safety, it's essential for the worker to know and apply the instructions described at the Instructions Manual delivered with the platform.
- Don't exceed the Weight Load Limit or the number of people indicated at the platform's nameplate.
- Stop the works and put the platform on the ground if wind's velocity exceeds 14m/sec if it's a non guided platform or 16m/sec if it's a guided platform. Don't work with storm weather.
- If it's raining verify the engine's brake of the e.lift in order to avoid glidings.
- Before each start up, the machine must be verified by a competent person.
- A maintenance operation must be realized annually by Accessus.

Electric cabinet nameplate (3)

NºSerie / Serial nº:     **E-XXXXX**

Año / Year:     **20XX**

Tensión nominal / Nominal voltage:  
**3X400/230V±10%, 50/60Hz**  
(3F+N+T, 50/60Hz)

Tensión de mando / Control voltage:     **24/48V**  
I,max admisible / Max.admissible I:     **16A**  
Poder de corte / Cutting power:     **6000A**

accessus

c/Energia 54  
08940 Cornellà de Llobregat, Barcelona - SPAIN  
Telf.: (+34) 93 475 17 73  
accessus@accessus.es     www.accessus.es



### 13-Disposal and environmental protection

The equipment is made from recyclable materials. If the equipment is later scrapped, it must be disposed off correctly. The national versions of the waste legislation Directive 75/442/CEE apply within the European Union.

In accordance with Directive 2002/96/CE, the manufacturer is obliged to take back and dispose of specific pneumatic and electronic components. The following symbol is used on the nameplate of such components to identify them:



## 14-Model for Declaration of Conformity.

Declaración CE de conformidad	EC Declaration of conformity	Déclaration de conformité CE	Declaração CE de conformidade
Conforme al anexo II. 1. A de la Directiva Máquinas 2006/42/CE	According to annex II 1, A of European Directive 2006/42/EC	Conformément à l'annexe II 1, A de la directive européenne 2006/42/CE	De acordo com o Anexo II. 1. A da Directiva Máquinas 2006/42 / CE
Modelo / Model / Modèle / Modelo: <b>MODUBLADE</b>		Nº de serie / Serial Nº / Nº en série / Nº de série: <b>200009-XXXXX</b>	
Equipado con / Equipped with / Equipé / Equipado com		e.lift501 Nº: XXXX, SECURICHUTE600 Nº: XXXX, Armario eléctrico, Control box, boîtier de commande, Armário eléctrico Nº E-XXXXX	
El fabricante: / The manufacturer: / Le fabricant: / O fabricante:		ACCESUS PLATAFORMAS SUSPENDIDAS, S.L. C/Energía 54, 08940 Cornellà de Llobregat (Barcelona) – SPAIN Telf.: (+34) 93 475 17 73 - Email: <a href="mailto:accessus@accessus.es">accessus@accessus.es</a> - Web: <a href="http://www.accessus.es">www.accessus.es</a>	
<p>Declaro que la plataforma suspendida temporal (TSP) mencionada, cumple con todas las disposiciones aplicables de la Directiva Europea <b>2006/42/CE</b> relativa a las máquinas;</p> <p>La máquina es idéntica al modelo que ha obtenido la certificación CE de tipo siguiente:</p>	<p>Declares that the mentioned temporary suspended platform (TSP), complies with all relevant provisions of the European Directive <b>2006/42/EC</b> on machinery;</p> <p>The machine is identical to the model that has obtained CE certification of the following type:</p>	<p>Il précise que la plate-forme temporaire en suspension (TSP) est conforme au-dessus de toutes les dispositions applicables de la directive européenne <b>2006/42/CE</b>;</p> <p>La machine est identique au modèle ayant obtenu la certification CE du type suivant:</p>	<p>Declaro que a plataforma suspensa temporária acima mencionada (TSP) cumpre todas as disposições aplicáveis da Directiva Europeia <b>2006/42/CE</b>;</p> <p>A máquina é idêntica ao modelo que obteve a certificação CE tipo seguinte:</p>



CE tipo N° / CE type N°	CE-0056-MD-ACC-001-18-ESP	
Organismo notificado / Notified body / Organisme notifié	ECA, Entidad Colaboradora de la Administración, S.L. Unipersonal, Camí Can Ametller, 34 Edif. Bureau Veritas, 080195 Sant Cugat del Valles (Barcelona) SPAIN, nº0056;	
Cumple también con todas las disposiciones aplicables de las siguientes Directivas Europeas: / Complies also with all relevant provisions of the following European Directives: / Conforme à toutes les dispositions pertinentes des Directives Européennes suivantes: / Cumpre também todas as disposições aplicáveis das seguintes directivas europeias	2006/95/EC 2004/108/EC	
Cumple las disposiciones de las siguientes normas armonizadas: / Complies also with all applicable requirements of the following standards: / Conforme aux dispositions des normes harmonisées suivantes: / Cumpre os seguintes padrões harmonizados:	EN ISO 12100:2010 EN 1808:2015.	
Los datos de la persona facultada para elaborar el expediente técnico son: / The person authorized to compile the technical file is: / Les données de la personne autorisée à constituer le dossier technique sont les suivantes: / Os dados da pessoa autorizada a preparar o arquivo técnico são:	XXXXXXXXXXXXXXXXXX XXXXXXXXXXXXXXXXXX	
Nombre: / Name: / Nom / Nome: XXXXXXXXXXXXXXXXXXXX	Firma / Signature / Signature / Assinatura:	
Cargo: / Charge: / Bureau / Posição: XXXXXXXXXXXXXXXXXXXX		
Lugar y fecha: / Place and date: / Lieu et date / Lugar e data: XXXXXXXXXXXXXXXXXXXX, XX/XX/XXXX		







**15.1-Diary inspection info.**

This inspection info es preliminary, ACCESUS will not take responsibility for his content or notes.

It's obligatory to read and assimilate the indications described in this manual before the use or the maintenance of the platform.

Responsible of the inspection					
Company					
Date					
Place					
Indicate the Serial Number of the machine and his components.					
	Model	Serial number		Model	Serial number
Platform			Fall arrest device		
Hoist			Electric cabinet		
Wire ropes	Length:		Length:		

Ref.	Description	OK	NOT OK		Comments
			Reparable	Not reparable	
0	Ensure that the anchor points have sufficient capacity to withstand the stresses due to suspended loads. (See 6.1)				
0.1	-				
1	Platform				
1.1	Cleaning				
1.2	Welds				
1.3	Handrails				
1.4	Floor				
1.5	Upper limit switch				
1.6	Upper limit disc				
2	Elevation hoist				
2.1	Cleaning				
2.2	Noise				
2.3	Vibrations				
2.4	Plug				
3	Fall arrest device				
3.1	Cleaning				
3.2	Emergency stop				
4	Electric cabinet				
4.1	Emergency stop				
5	Wire ropes				
5.1	Hook				
5.2	Damage				
6	Electric hoses				
6.1	Plugs and connectors				

**If you detect one or more points NOT OK, the platform must be immobilized and prevent his use until resolve the defects.**

### 15.2-Periodic inspection info.

This inspection info es preliminary, ACCESUS will not take responsibility for his content or notes.

Is obligatory to read and assimilate the indications described in this manual before the use or the maintenance of the platform.

Responsible of the inspection		
Company		
Date		
Place		
Indicate the Serial Number of the machine and his components.		
	Model	Serial number
Platform		
Hoist		
Fall arrest device		
Electric cabinet		
Wire ropes	Length:	Length:

Ref.	Description	OK	NOT OK		Comments
			Reparable	Not reparable	
0	Ensure that the anchor points have sufficient capacity to withstand the stresses due to suspended loads. (See 6.1)				
0.1	-				
1	Platform				
1.1	Cleaning				
1.2	Welds				
1.3	Handrails				
1.4	Floor				
1.5	Upper limit switch				
1.6	Upper limit disc				
2	Elevation hoist				
2.1	Cleaning				
2.2	Crankcase				
2.3	Connection box				
2.4	Brake start up				
2.5	Noise				
2.6	Vibrations				
2.7	Fastenings				
2.4	Plug				
3	Fall arrest device				
3.1	Cleaning				
3.2	Emergency stop				

Ref.	Description	OK	NOT OK		Comments
			Reparable	Not reparable	
4	Electric cabinet				
4.1	Emergency stop				
4.2	Upper limit switch				
5	Wire rope				
5.1	Diameter				
5.2	Hook, cierre gancho				
5.3	Wear				
5.4	Broken strands				
5.5	Tip				
6	Electric hoses				
6.1	Plugs and connectors				
6.2	Cut				
6.3	Connection				
6.4	Bridle of subjection				
6.5	Adequated section				

**If you detect one or more points NOT OK, the platform must be immobilized and prevent his use until resolve the defects.**

**The elevation hoist, fall arrest device and electric cabinet must be checked by ACCESUS once a year.**



accessus®

NUEVO CATÁLOGO  
PARA TRABAJOS  
EN ALTURA



## ARNESES

· Arneses homologados con anclaje frontal y/o dorsal, con o sin cinturón de posicionamiento, ignífugos, aptos para trabajos en suspensión, diseñados para mujer, de alta visibilidad...

· Arnese de gama alta desde 55 €.



## ESLINGAS

· Disponibles con o sin conectores, regulables, dobles, con o sin absorbedor de energía, ignífugas, de cuerda o cinta elásticas...

· Eslingas con distintas longitudes y precios a partir de 6 €.



## ANTICAÍDAS Y DESCENSORES

· Anticaídas de cuerda, anticaídas retráctiles de cable de acero, anticaídas retráctiles con rescatador, descensores de emergencia con manivela para ascenso...

· Anticaídas con longitud de cable hasta 60 m.

Solicítelo por teléfono en el (+34) 93 475 17 73  
o bien a través del correo [accessus@accessus.es](mailto:accessus@accessus.es)

También puede descargarlo en:  
[www.accessus.es/es/catalogos](http://www.accessus.es/es/catalogos)



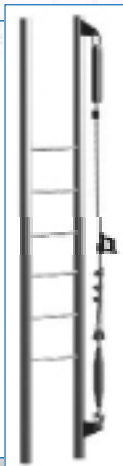

## LÍNEAS DE VIDA

- Líneas de vida temporal de cinta horizontal, cuerdas de vida a ignifugas y regulables, distintas longitudes...
- Disponibles en distintas configuraciones.



## TRÍPODES Y BRAZOS DE RESCATE

- Gamadetrípodesdeseguridady brazosderescatequegarantizanlaprotección anticaídas y el rescate seguro de personas.
- Con distintas configuraciones y accesorios opcionales.



Solicítelo por teléfono en el (+34) 93 475 17 73  
o bien a través del correo [accesus@accesus.es](mailto:accesus@accesus.es)  
También puede descargarlo en:  
[www.accesus.es/es/catalogos](http://www.accesus.es/es/catalogos)



## VARIOS

- Puntos de anclaje fijos temporales, mosquetones y ganchos de distintos tamaños, sillas de trabajo, camillas de rescate...
- Amplio surtido de accesorios de seguridad.





accessus

PLATAFORMAS SUSPENDIDAS

C/Energia 54

08940 Cornellà de Llobregat (Barcelona), SPAIN

Tel.: (+34) 93 475 17 73

[www.accessus.es](http://www.accessus.es)

[accessus@accessus.es](mailto:accessus@accessus.es)