

Rescue stretchers

C R 0 2 0

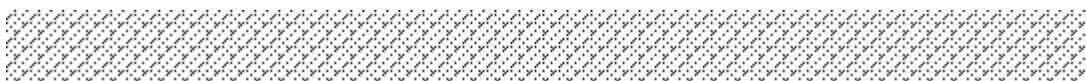

Ref No: CR020

Essential Features

Material: PVC + PS + stainless steel
Load capacity: 500 kg
Scope of working temperature: -30/+50

The stretchers are made of extraordinarily resistant and flexible plastic; dimensions: 200x90 cm. The plastic is featured by resistance to: abrasion, discoloration by physiological fluids, antibacterial properties of the surface and resistance to UV radiation. The material is resistant to disinfectants.

The whole set is held in a special ergonomic transport backpack, to facilitate its transport both in the open and in narrow spaces.

The DX020 set consists of:

1. Stretchers
2. Transport backpack with catch grips
3. Two slings of different lengths for horizontal transportation of the injured
4. Snap hook AZ018
5. Four grips to increase the number of persons to lift the injured
6. A 10.5 mm diameter and 7 m long lanyard for vertical transportation of the injured
7. Rehab roll placed under knees of the injured



Set proportion

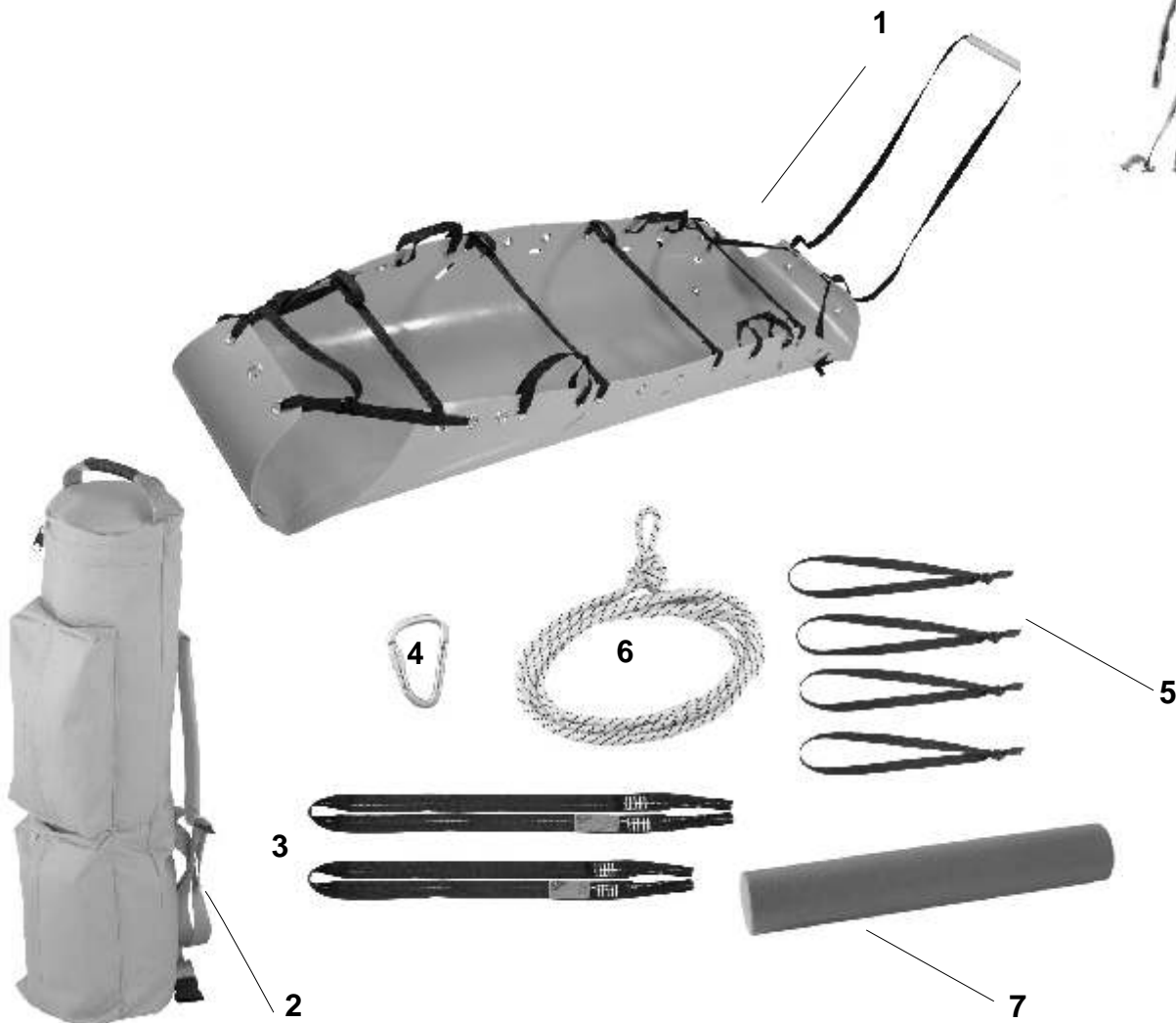

Ref No: CR020

Stretchers handling

Prior to use take the stretchers out of the transport backpack (A). Lay the stretchers down on a flat surface and loosen the clamping webbings (B). Unwind the roll (C). Following the loosening of webbings, overbend the plastic on each side to overcome its tendency to roll up again (D-F).

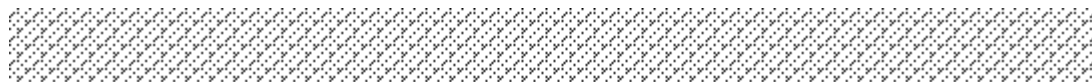

Ref No: CR020

Handling of the stretchers and the injured

Place the stretchers along the injured as near as possible (G). Place the injured on the stretchers with utmost care (H).



Laying down the injured

Lay down the injured on their back on the evenly spread plastic, placing their head in the direction of webbings designed for pulling the injured; the webbings are fitted with an anti-slip handle (I). When the injured is in place, model the shape of the stretchers (J) with the use of the clamping belt system provided with special buckles (K).



Ref No: CR020

Horizontal transportation of the injured

The stretchers should be clamped laterally by 4 webbings (L) with the use of special buckles (M), then the webbings should be clamped in the vicinity of the legs and head by slipping them through openings (N) and pulling them to form the proper shape of the stretchers (O). The stretchers are intended for horizontal transportation of the injured by one person by pulling them along a flat or slightly sloped surface (P).



Ref No: CR020

Horizontal transportation of the injured

Horizontal transportation of the injured on surfaces with a bigger angle of slope requires the assistance of at least 4 persons with the use of 4 transportation grips (R). Stretchers DX020 are also intended for suspending below a helicopter with the use of slings with two different lengths, allowing maintaining the head above the feet level (S). At one point the slings should be clamped with an AZ018 snap hook, which will thus form a catch for connecting to the hoisting winch of the helicopter or to the transportation line (T). Where necessary, the stretchers may be adjusted for carrying by 8 persons, by adding additional grips, included in the set, which are inserted in the free openings.

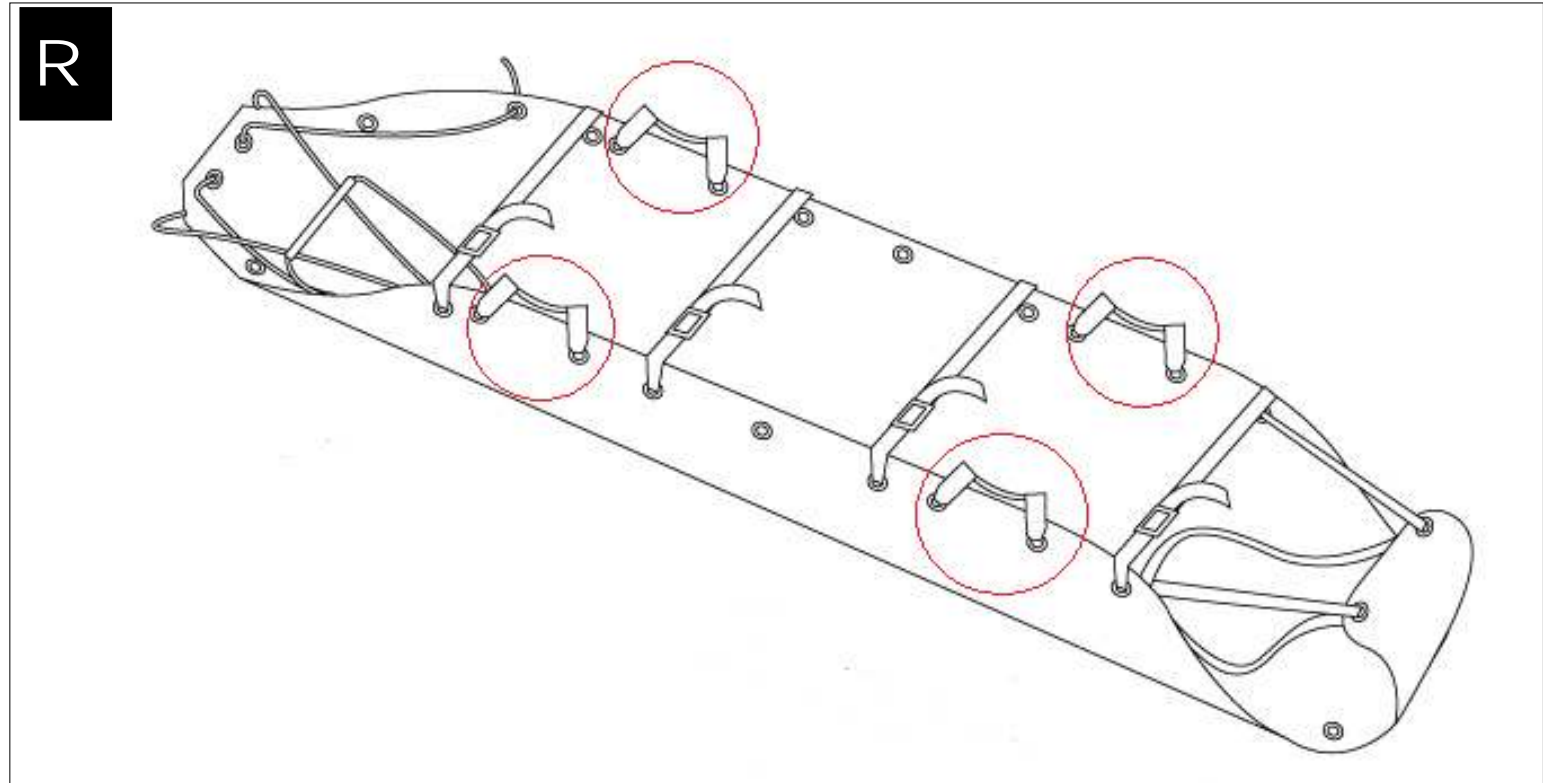

Ref No: CR020

Vertical transportation of the injured

In order to transport the injured vertically, when the stretchers are ready to use (O) it is necessary to slip a lanyard through the free openings in the circumference of the stretchers, as shown in figure (U). In the middle of the lanyard a "figure eight" knot should be done to provide a catch point (W), and another, self-locking one, the so-called fisherman's knot (X).

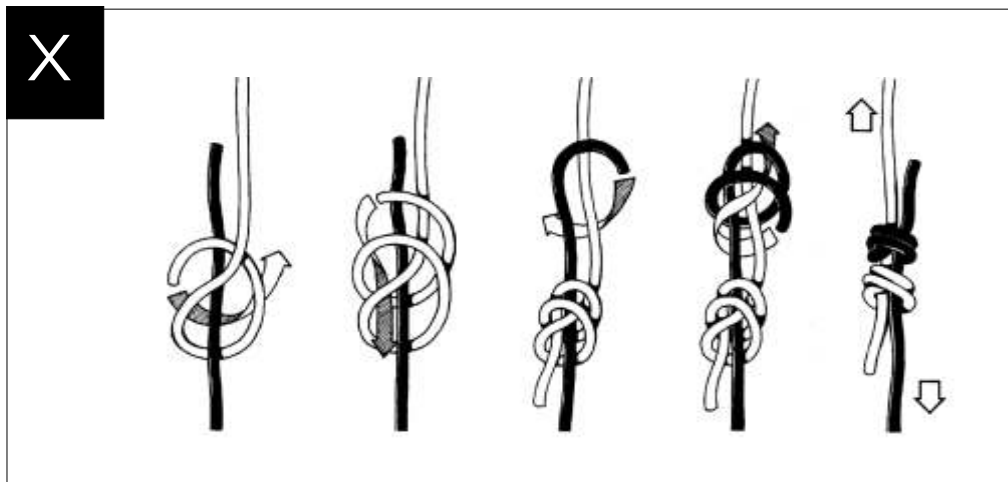
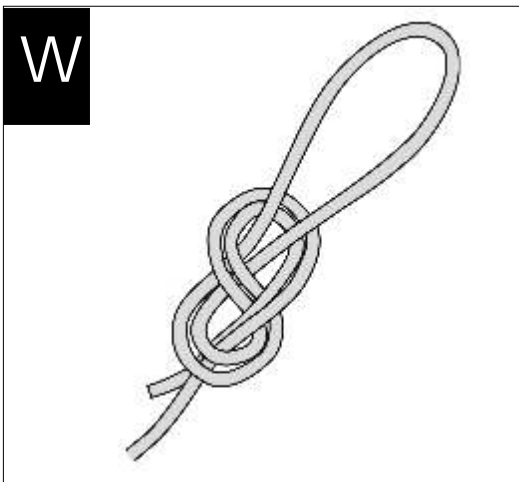
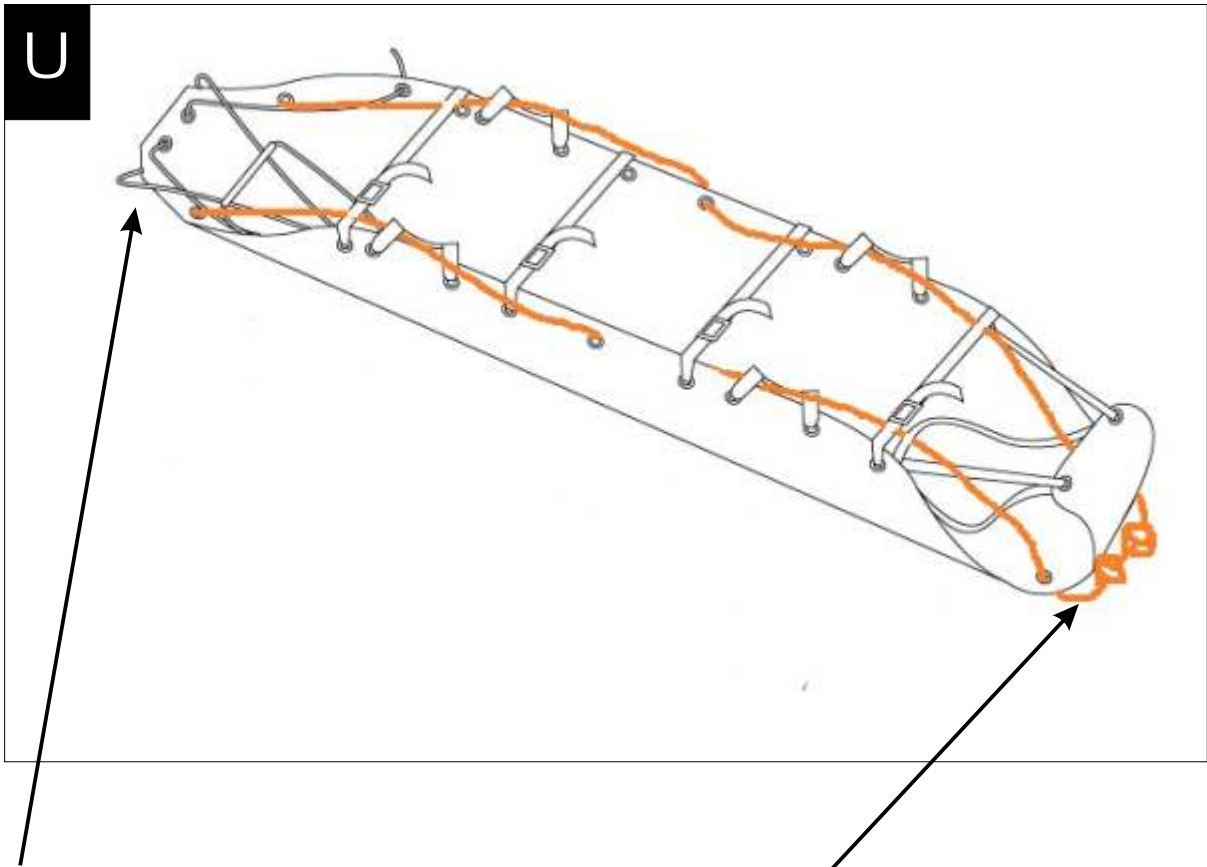

Ref No: CR020

General information

- The equipment should be used solely by persons trained in its use.
- The equipment shall not be used by persons, whose condition of health may affect safety during everyday or emergency use.
- It is necessary to prepare an emergency action plan which will be ready for use in case of a need.
- Any modifications to the equipment without written permission from the manufacturer shall be forbidden.
- Any repairs of the equipment may only be done by the manufacturer of the equipment or its duly authorized representative.
- The equipment cannot be used for applications other than intended.
- Prior to use make sure that all the components of the system work properly. Make periodical checks of connections and fit of the components of the equipment to avoid accidental loosening or disconnection.
- Never use any set in which the operation of any component is disturbed by another.
- All components of the equipment should meet the requirements of respective regulations and instructions for use of the equipment, as well as all effective standards.
- Prior to every use the equipment should be carefully visually inspected to check its condition and proper operation. The visual inspection shall be done by the user of the equipment.
- During the visual inspection it is necessary to check all components of the equipment, with particular focus on any damage, excessive wear, corrosion, abrasion, cuts or incorrect operation. Particular attention should be paid to:
 - -buckles, adjusting elements, attaching points (buckles), webbings, seams, loops, connectors.
- At least once a year, after every 12 months of use, the protective equipment should be withdrawn from use to carry out detailed periodical inspection. The periodical inspection may be carried out by the person who is responsible in the facility for periodical inspections of the protective equipment and trained accordingly. Periodical inspections can also be carried out by the manufacturer of the equipment or by a company authorized by the manufacturer. It is necessary to carefully check all components of the equipment, paying particular attention to any damage, excessive wear, corrosion, abrasion, cuts or incorrect operation (see the previous point). In certain cases, where the equipment has a complex structure, the periodical inspections can only be carried out by the manufacturer of the equipment or by its authorized representative. Upon completion of the periodical inspection the date of the next inspection shall be determined.
- Regular periodical inspections are essential in terms of the condition of equipment and safety of the user, which depends on full efficiency and durability of the equipment.
- During the periodical inspection it is necessary to check legibility of all protective equipment marking (feature of the given piece of equipment).
- All information about the equipment (type, serial number, date of purchase and commissioning, name of the user, information about repairs and inspections and withdrawal from use) must be entered into the given equipment identity card. Entries in the identity card are the responsibility of the work facility in which the equipment is used. The card is filled in by the person who is responsible for protective equipment in the facility. Use of the equipment without a filled in identity card is forbidden.
- Where the equipment is sold beyond the territory of the country of its origin the supplier of the equipment shall provide it with instructions for use, instructions for maintenance and information about the periodical inspections and repairs in the language of the country where it will be used. The equipment shall be immediately withdrawn from use when any doubts arise as to the condition of the equipment or its proper performance. The equipment shall be released for use again only after a detailed inspection by the manufacturer of the equipment and its written consent to reuse the equipment.
- During the use of the equipment particular attention should be paid to dangerous phenomena affecting the performance of equipment and the user's safety, with particular focus on:
 - lanyard looping or trailing over sharp edges;
 - pendulum falls;
 - electrical conductivity;
 - any damage such as cuts, abrasion, corrosion;
 - extreme temperature impact;
 - climatic exposure.
- Action of aggressive substances, chemicals, solvents, acids.
- The equipment must be transported in packaging which protects it against damage or moisture, e.g. in bags made of impregnated fabric or in steel or plastic suitcases or crates.
- Protective equipment should be cleaned and disinfected so as to avoid damage to the material (raw material) from which the equipment is made. Textile materials (webbings, lanyards) should be cleaned with cleaning agents for delicate fabrics. They can be cleaned manually or in a washing machine. They should be rinsed thoroughly. Parts made of plastics can only be washed in water. The equipment which is wet after cleaning or after use should be dried thoroughly in natural conditions, away from sources of heat. Metal parts and mechanisms (springs, hinges, pawls, etc.) may be periodically slightly lubricated to improve their operation.
- The equipment should be stored in loose packaging in well ventilated, dry space, protected against light, UV radiation, dust, sharp objects, extreme temperatures and caustic.

IDENTITY CARD

MODEL AND TYPE OF EQUIPMENT	
-----------------------------	--

REF. NUMBER	
-------------	--

SERIAL NUMBER		DATE OF MANUF.	
---------------	--	----------------	--

USER NAME	
-----------	--

DATE OF PURCHASE		DATE OF PUTTING INTO OPERATION	
------------------	--	--------------------------------	--

PERIODIC EXAMINATION AND REPAIR HISTORY

	DATE	REASON FOR ENTRY PERIODIC EXAMINATION OR REPAIR	DEFECTS NOTED, REPAIRS CARRIED OUT AND OTHER RELEVANT INFORMATIONS	NAME AND SIGNATURE OF COMPETENT PERSON	PERIODIC EXAMINATION NEXT DUE DATE
1					
2					
3					
4					