

**TRANSLATION OF THE ORIGINAL  
OPERATING INSTRUCTIONS MANUAL**  
This manual must be always available for the user.  
Additional copies may be obtained on request.



**Index:**

1-Information for this manual	4
2-Explanation of symbols used in this manual	4
3-General.	5
3.1-Glossary and abbreviations used in this manual	5
4-Previous instructions and warnings	6
5-Machine's description.	8
5.1-Area of application.	8
5.2-TSP equipment.	8
5.3-Main components	9
6-Setting up	10
6.1-Efforts due to suspended loads	10
6.2-Configuration / dimensions	10
6.3-Assembly of the platform	11
6.4-Electric components	20
6.5-Introduction of the wire ropes in the platform	21
6.6-Running test	25
7-Safety devices	27
7.1-Integrated safety devices in electric hoist e.lift501	27
7.2-Integrated safety devices in electric cabinet	27
7.3-Fall arrest device system securichute600	28
7.4-Overload safety device system in e.lift501	29
7.5-Upper and final limit switch in e.lift501	29
7.6-Phase controller	30
7.7-Emergency descent in e.lift501	30
7.8-Acoustic bleeper (optional)	30
8-Operating the platform	30
8.1-Preliminary checks	30
8.2-Rated capacity	33
8.3-Loading / unloading areas	33
8.4-Electric controls.	34
8.5-No power emergency descent	35
8.6>Action in case of the fall arrest locking	36
8.7-Request for help with the acoustic bleeper (optional)	36
8.8-Platform leveling	37
8.9-Moving the platform horizontally	39
8.10-Removing the wire ropes	40
8.11-Dismantling the platform	41
9-Resual risks not covered by the design of the TSP	42
10-Troubleshooting	42
11-Maintenance	45
11.1-Wire ropes	46
11.2-Elevator	47
11.3-Fall arrest device securichute	48
12-Spare parts	48
12.1-Komplet 211062 platform.	48
12.2-Elevator	48
12.3-Fall arrest device securichute600	48
12.4-Electric cabinet	48
12.5-Nameplates and labels	49
13-Disposal and environmental protection	50
14-Model for Declaration of Conformity	51
15-Machine's historic	52
15.1-Daily inspection report	52
15.2-Periodic inspection report	55



**DANGER!**

**Risk of wound and injuries due to fall of objects, failure, incorrect application and/or incorrect utilization.**

Read the whole operating instructions manual before the assembly and set up of the platform. Follow the instructions and procedures described in this manual in order to ensure a safety utilization of the equipment.

**1- Information for this manual:**

<b>Date of edition:</b> 1th Edition: 02/2020	<b>Manufacturer:</b> <b>ACCESUS plataformas suspendidas, S.L.</b> C/Energia 54 08940 Cornellà de Llobregat (Barcelona) Telf.: (+34) 93 475 17 73 www.accesus.es accesus@accesus.es
<b>Copyright:</b> All rights reserved.	

**2- Explanation of symbols used in this manual**



**DANGER!**

**Type and origin of danger**

Result: for example fatal or serious injuries.

-Solutions to eliminate the danger.



**IMPORTANT!**

**Type and origin of danger**

Result: for example damage to machines or the environment.

-Solutions to eliminate any possibility of accidents



**NOTE**

Useful tips for optimum working. Instructions to operation / documentation in writing.



### 3- General:

This operating instructions manual is destined to the workers of the described machine. This operating instructions manual must be accessible to workers every time. Request more copies if it's necessary.

ACCESUS Plataformas Suspendidas S.L. saves the rights to modify the product described in this manual as a part of his continued improvement.

The clients can obtain more information about other ACCESUS products, demanding the documentation through address described at section 1 of this instructions manual. Please, check our website: [www.accesus.es](http://www.accesus.es).

#### 3.1-Glosary and abbreviations used in this manual:

<b>W.L.L.</b>	Working Load Limit.
<b>Electrician</b>	A professional worker who knows and has the correspondent and necessary qualification to know the risks and to avoid the danger that has an electrical environment.
<b>Worker</b>	A person who works professionally with the machine.
<b>TSP</b>	Temporary Suspended Platform.
<b>Exploiter</b>	The responsible for both the regulatory operation of the installation of the device and compliance with maintenance intervals and repair works.

## 4- Previous instructions and warnings:

- TSP (Temporary Suspended Platforms) is destined exclusively to a **professional use**. Must be destined only to qualified people with knowledge for set up and utilization. Workers must be prepared for works at heights. Workers must know and assimilate the Law of Labor Risk Prevention.
- The machine must be dismantled and stored at the end of the works.
- For a safety utilization the TSP requires at least 2 workers at the same time.
- This TSP can only be used by authorized staff with adequate formation and psychologically suitable. Keep out from unauthorized people.
- Before to install and use a TSP is essential, for safety and efficiency, **to read and assimilate all the contents of this manual** and proceed in agreement to this instructions. Likewise, before the service, it's important to read all the labels fixed on the machine.
- This manual must be conserved in good condition and always be available for all workers who use the TSP.
- In case of loss or deterioration of the labels, these must be replaced before the use of the machine. Request more copies of the instructions manual and labels if it's necessary.
- The responsible company must **apply the regulation of safety** relative to the assembly, utilization, maintenance and technical controls referred to all the equipment. The responsible company must give the instructions to the workers and verify his aptitudes.
- Before putting in service the platform, the person in charge of work, must verify and ensure the good condition of the TSP equipment.
- Don't use a TSP or an accessory (wire rope, suspension points, etc.) in bad condition. A **periodic control** of the machine by an authorized person is essential for safety. The maintenance not described in this manual must be realized by the manufacturer or by an authorized repairer.
- Don't use the equipment for other uses than the indicated in this manual. The manufacturer can't guarantee the product for other configurations not described in this manual. For other applications consult the manufacturer or a professional specialized technician before proceeding to assembly the equipment.
- **Don't use the TSP beyond the limits of utilization** described in this manual and the platform manufacturer, and specially don't exceed the rated load of use indicated in the labels.
- Apart from the instructions indicated in this manual, the manufacturer declines any responsibility for the consequences of a disassembly of the devices, modifications or manipulations, specially in case of substitution of the original pieces by others from different origin.

- This TSP has a life of 10 years. This duration is based on a utilization of the platform according to the instructions of this manual of 200 hours per year and with the condition that the annual reviews effect.

- A special care is needed by dangers that will appear when the TSP is over water, public areas or where it's not possible to get the platform down to a safe position.

- When planning the work, the climatic and wind characteristics of the site must be taken into account: in case of doubt, check the weather and wind conditions in the meteorological service before starting work.

- Don't use the TSP in severe conditions such as atmospheric extreme conditions, corrosive environments, magnetic fields, explosive atmospheres (ATEX), works under tension, works in low voltage network, etc.

- A special care is needed due to dangers derived from work with TSP in confined spaces.

- In the vicinity of the winch it is necessary to use hearing protection.

- Don't use the TSP for loads which can generate dangerous situations (for example: molten metal, acids, radioactive materials, etc.)

- For platforms employed at heights upper than 40 m and exposed to winds over 50km / h, they must limit the lateral movements by a guide system, composed by anchorages each 20m.

- A special care is needed by dangers that will appear when the loads are manipulated.

- **In some countries of the European Union is obligatory an inspection before the putting in service of a new work. This control must be realized by an authorized organism.**

- **To cover risks arising from misuse, it is necessary the use of personal protective equipment (PPE) fall arrest by operators. See section 8.1 of this instructions manual.**

- **The elaboration of the procedure for entering a confined space is the responsibility of the company that uses the machine.**

#### **IMPORTANT:**

If you entrust this equipment to subcontracted personnel you have to apply and check his obligations about safety at work, specially for verifications and tests before the putting in service.

#### **RISK ASSESSMENT:**

According to 92/57/CEE, each contractor shall prepare a **Safety and Health** plan at work which analyses, studies, develops and supplements the previsions contained in the study or basic study, based on their own system of execution of the work.

## 5-Machine's description

### 5.1-Area of application

The machine described in this manual is destined to be used temporary for inspection and maintenance works for interior surfaces in sloping flat roofs (persons elevation and tools included), such as deposits.

The platform remains excluded for:

- Temporary suspended platforms equipped with elevators with a maximum capacity of use exceeding 500kg.
- Temporary suspended platforms suspended by 3 points or more.
- Suspended platforms designed for permanent installation in buildings.
- Platforms suspended from the hook of a crane.
- Explosive atmospheres (ATEX).

### 5.2-TSP equipment

The equipment described in this manual is composed by a steel suspended platform equipped with two e.lift501 powered hoist (with fall arrest device securichute600), suspended by steel wire ropes.

ACCESUS can also provide or advise in choosing of the most suitable roof beam or suspension structure. If you have a roof beam, ACCESUS can study your case and document it so you can use the aluminium suspended scaffold safely and documents in order.

The limit of the equipment described in this manual are the hooks of work and safety wire ropes.

If this equipment does not adapt to your needs, ACCESUS can advise in the correct choice of a suspended scaffold and/or suspension structure for your specific case. If it's necessary we can design a bespoke solution for you.

The TSP includes all the safety devices to make a temporary suspended access installation covered by the declaration of conformity made by the manufacturer and according to the Machine Directive.

### 5.3-Main components

The main components are:

**Suspended platform Accesus KOMPLET 211062 manufactured in steel, composed by:**

- 1-Electric hoist **e.lift501**. (2 units),
- 2-Fall arrest device **securichute 600**. (2 units)
- 3-Electric cabinet for elift501 (1 unit),
- 4-Lower end panel (1 unit),
- 5-Upper end panel (1 unit)
- 6-Floor-stairs panels 3m (2 units)
- 7-Floor-stairs panels 2m (1 unit)
- 8-Works and safety wire ropes (4 units)
- 9-Side panels 3m (4 units)
- 10-Side panels 2m (2 units)
- 11-Handrails 3m (4 unid.)
- 12-Handrails 2m (2 unid.)
- 13-Lower elevator anchorage (1 unit)
- 14-Upper elevator anchorage (1 unit)
- 15-Electric cabinet support (1 unit)
- 16-Connection stirrup (2 units)

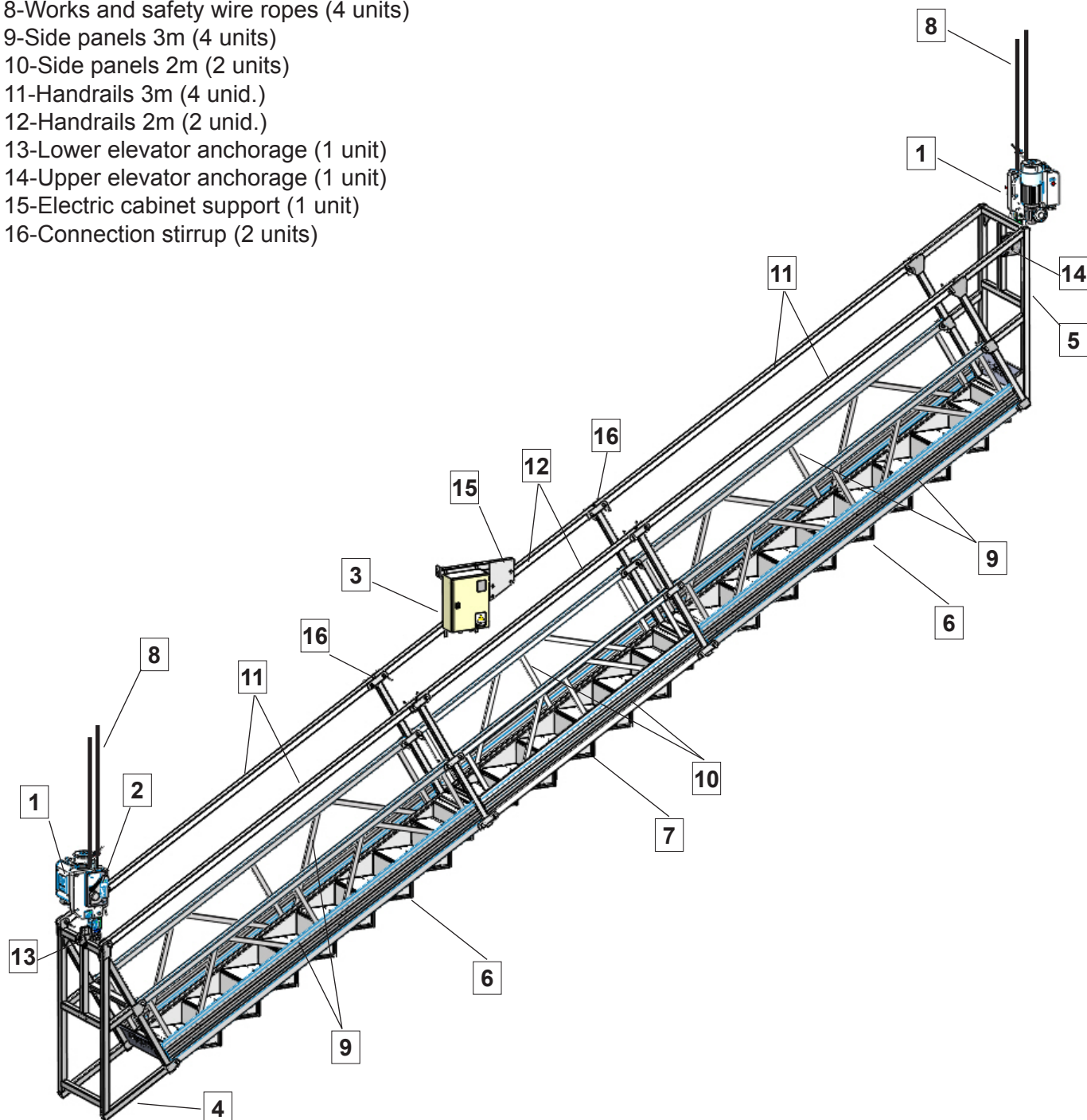

## 6-Setting up

### 6.1-Efforts due to suspended loads

The vertical reaction to the hooks of the wire ropes (work and safety) of the suspended scaffold Komplet 211062 is:

	E.lift 501
Reaction not-factored on hook (R)	500 kg

According to the UNE-EN 1808 standard, the anchor point must support the greater reaction with a safety factor of 3.

ACCESUS recommends the use of standard suspensions such as the Brakoo system, or the rest of the ACCESUS suspension range.

A qualified person must perform the calculations or load test and be the responsible of the structure's capacity to support the efforts due to the suspended loads.

ACCESUS recommends a test load for your special suspension structure in order to verify that the anchorage points are correct. ACCESUS proposes this service and gives you a certification of the load test.

### 6.2-Configurations / dimensions

The Komplet 211062 platform is a special platform of length 8m and width 700mm.

The following tables describe the configurations, load capacity and dead weight.

#### LOAD CAPACITY

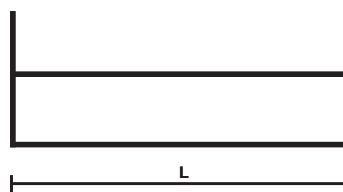

<b>Elevator</b>	<b>Platform length (m)</b>	<b>8</b>
<b>e.lift® 501</b>	<b>Weight load capacity (kg)</b>	<b>320</b>
	<b>Number of people</b>	<b>3</b>
	<b>Dead weight (kg)</b>	<b>550</b>

### 6.3-Assembly of the platform



#### IMPORTANT!

Risk of wounds and injuries due to fall of objects, fall from different level and / or breaks.

Danger of death due to fall of objects, fall from different level and / or breaks.

-Before the assembly of the wire ropes ensure that the supporting point have enough capacity to support the efforts of the suspended loads.

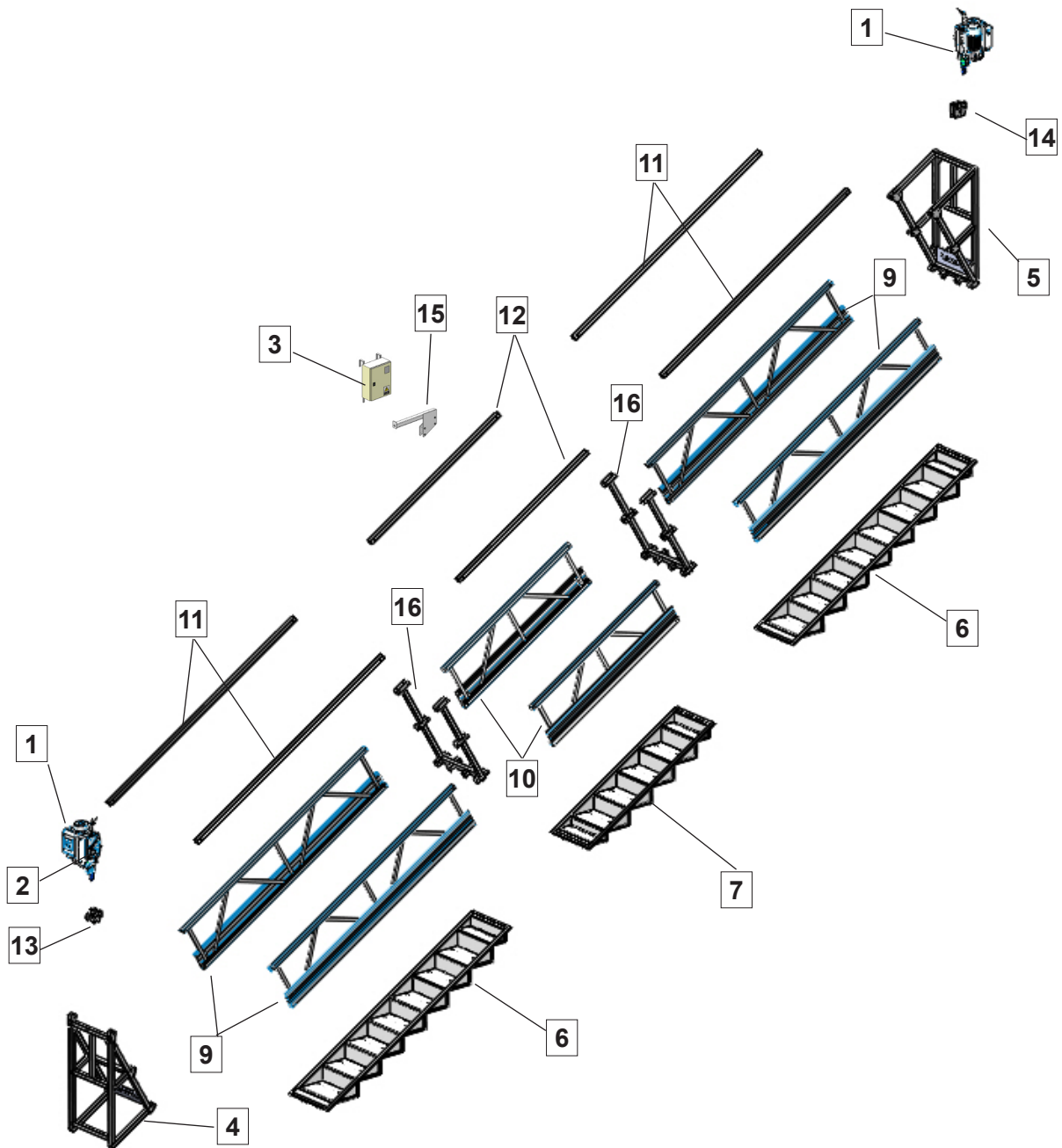



List of materials and necessary tools for the assemble:

Torque and ratchet wrenches for M10 and M12 hexagonal screws. 2 people.  
 - The following table shows the necessary fasteners and the correct torque setting::

	DESCRIPTION	TORQUE SETTING	UNITS
<b>T1</b>	Accesus fastener	-	36
<b>T2</b>	DIN931 M12x50 8.8 Screw + DIN985 Nut	62 Nm	4
<b>T3</b>	Screw DIN931 M12x90 8.8 + DIN985 Nut + 2 Washer DIN125	62 Nm	4
<b>T4</b>	Screw DIN931 M12x100 8.8 + DIN985 Nut + 2 Washer DIN125	62 Nm	10
<b>T5</b>	Screw DIN931 M10x80 8.8 + DIN985 Nut + 2 Washer DIN125	36 Nm	4

The assembly of the modules can be done with any of the following two types of fasteners:

-ACCESUS Nut fastener with safety DIN985 nut and DIN125 washer.

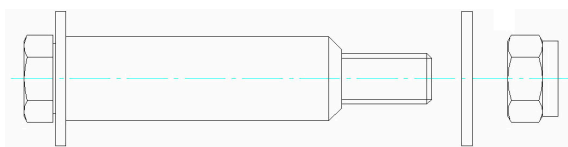

-ACCESUS fastener with safety clip.

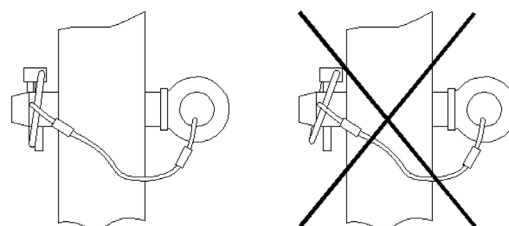
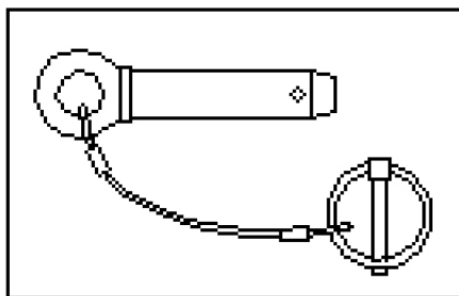



The assembly of the scaffolding with the location of the fastener is described below:

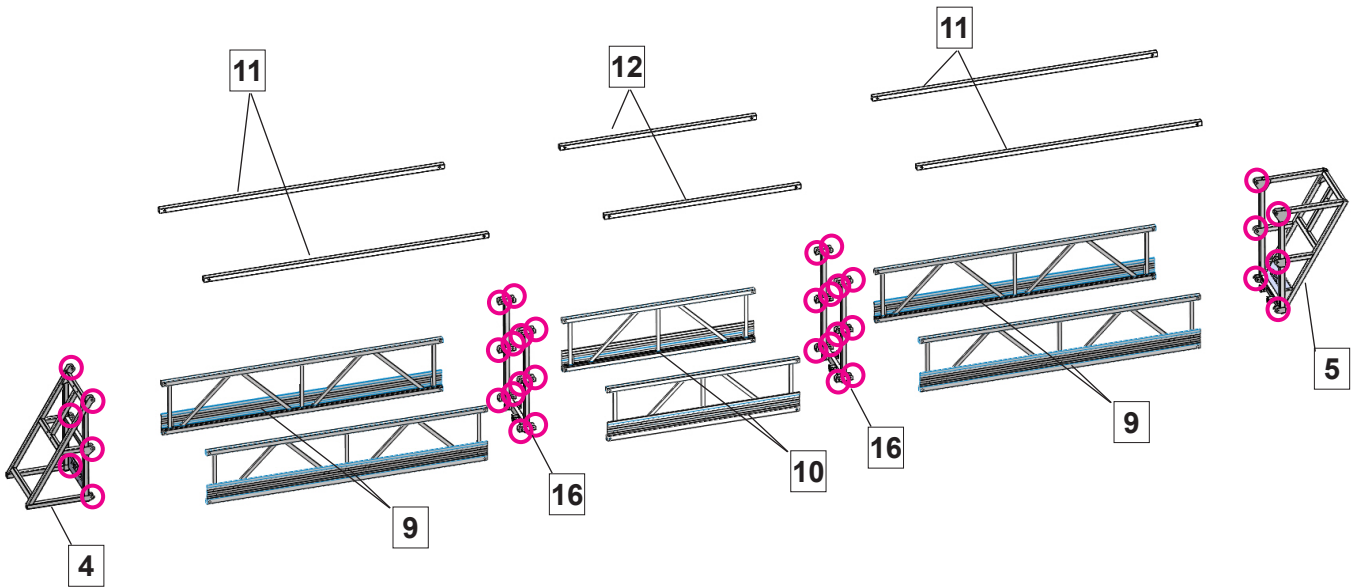

Then place the floors (6 or 7) and secure them with the 4 stops per floor. The tubes that protrude from the crossbar of the connection stirrup (16) or upper end (5), must fit to the ears that come out at the ends of the floors (6 or 7), from the bottom.

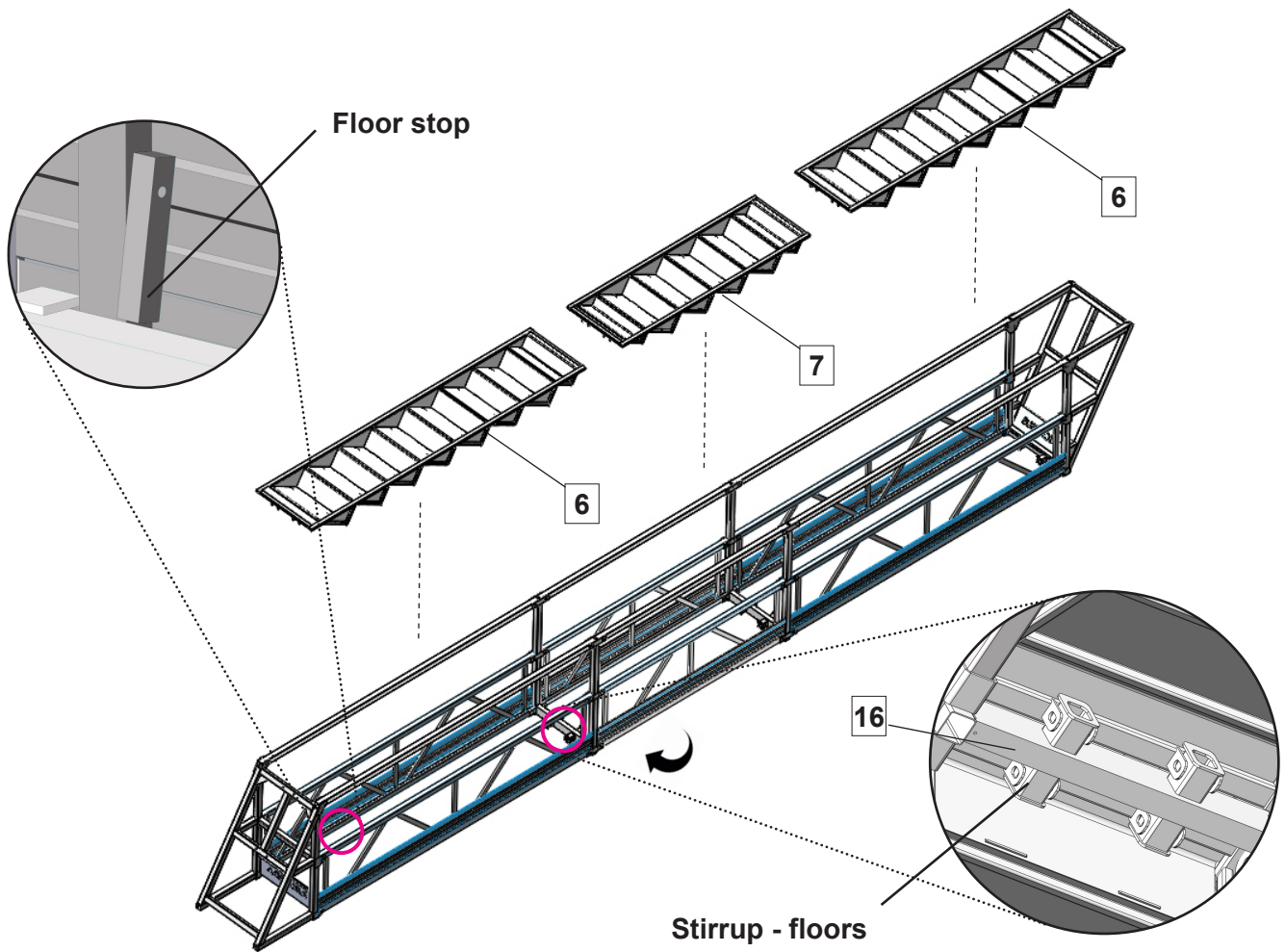

Pay attention to the orientation of the steps, where “x” is always longer than “y”. Support the platform at the ends to raise it about 15cm from the ground to assemble the floors.

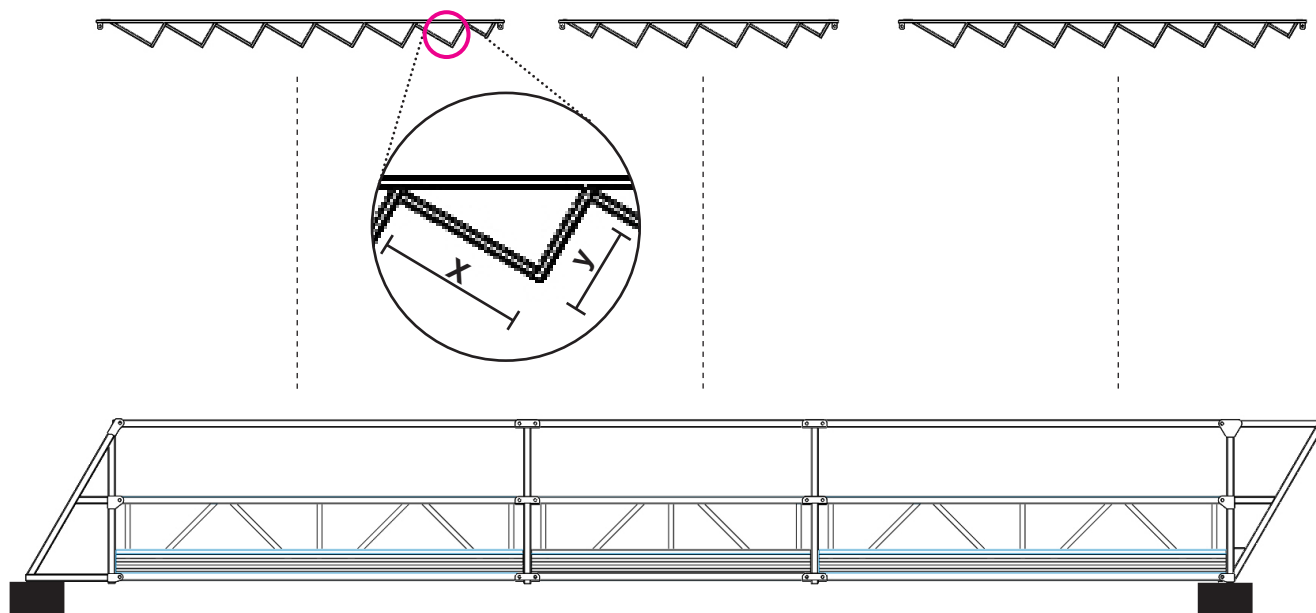

The outer floor frame (6 or 7) must rest on the lower projection of the lateral supports (9 or 10). Display next image where an end panel has been hidden in order to see the support mentioned.

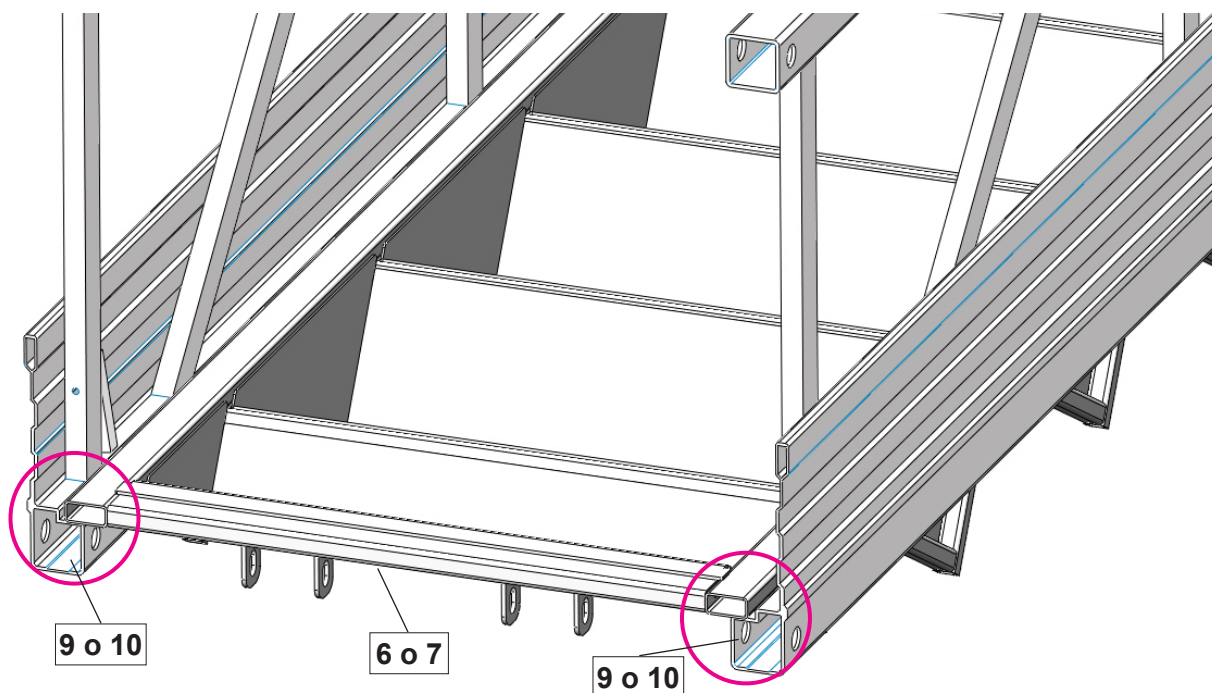

Fix the floors - stairs (6 or 7) with 4 T4 screws for each floor. The floor - stair (6 or 7) closest to the lower end panel (4) will only be secured by 2 T4 screws at the top with the connection stirrup (16).

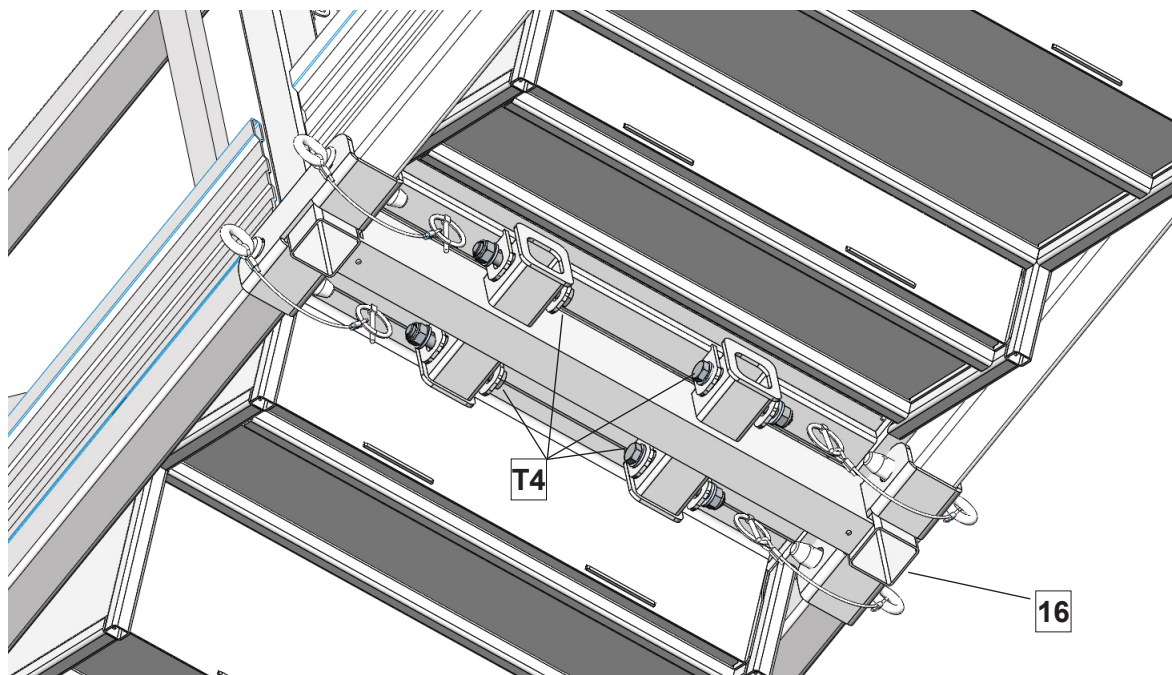

Place the elevator anchorage (13) in the lower end panel (4) using 2 T3 screws.

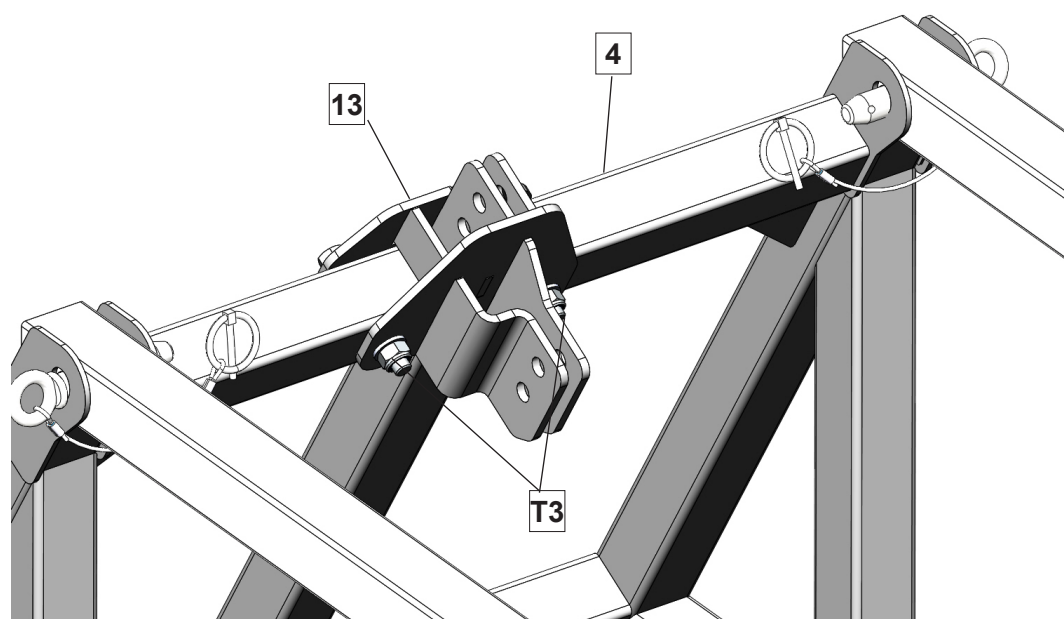

Place the upper anchorage on the upper end panel using 2 T3 screws

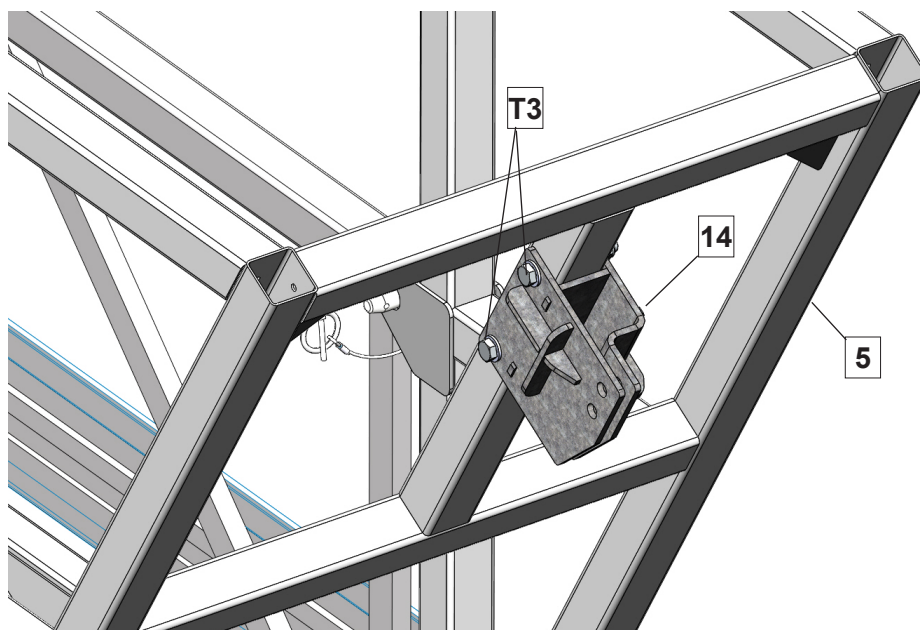

Then assemble the elevators using 2 T2 screws for each elevator. Each elevator is positioned so that the most protruding part of the elevator with respect to the anchors will face the outside of the platform, each rotated 180 degrees with respect to the other elevator.

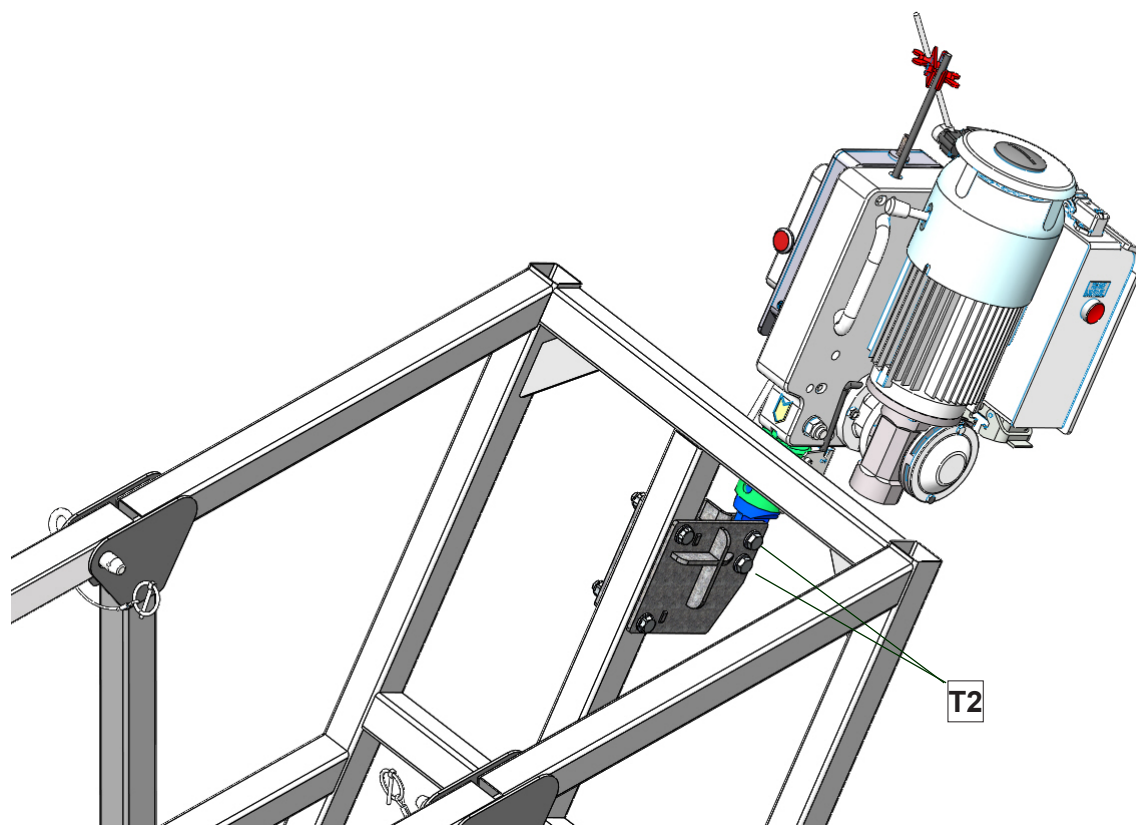



For the elevator located in the lower end panel (4) there are two possible anchors. In both cases the same 2 T2 screws are used.

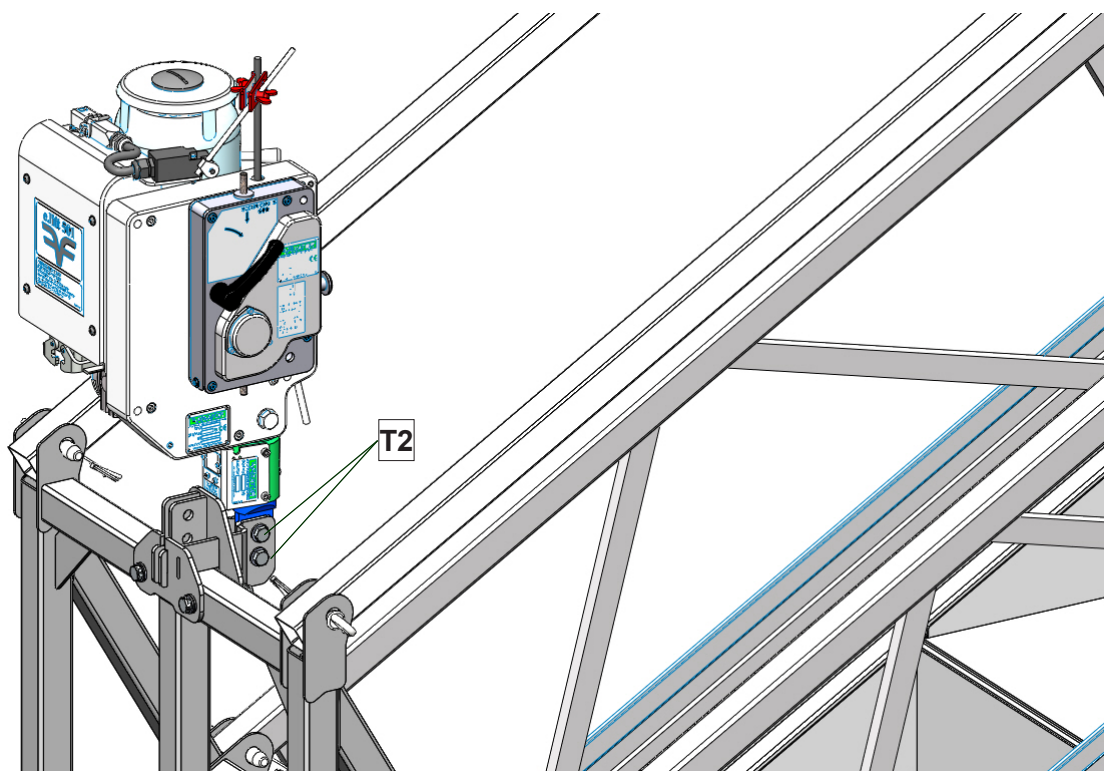

Internal position

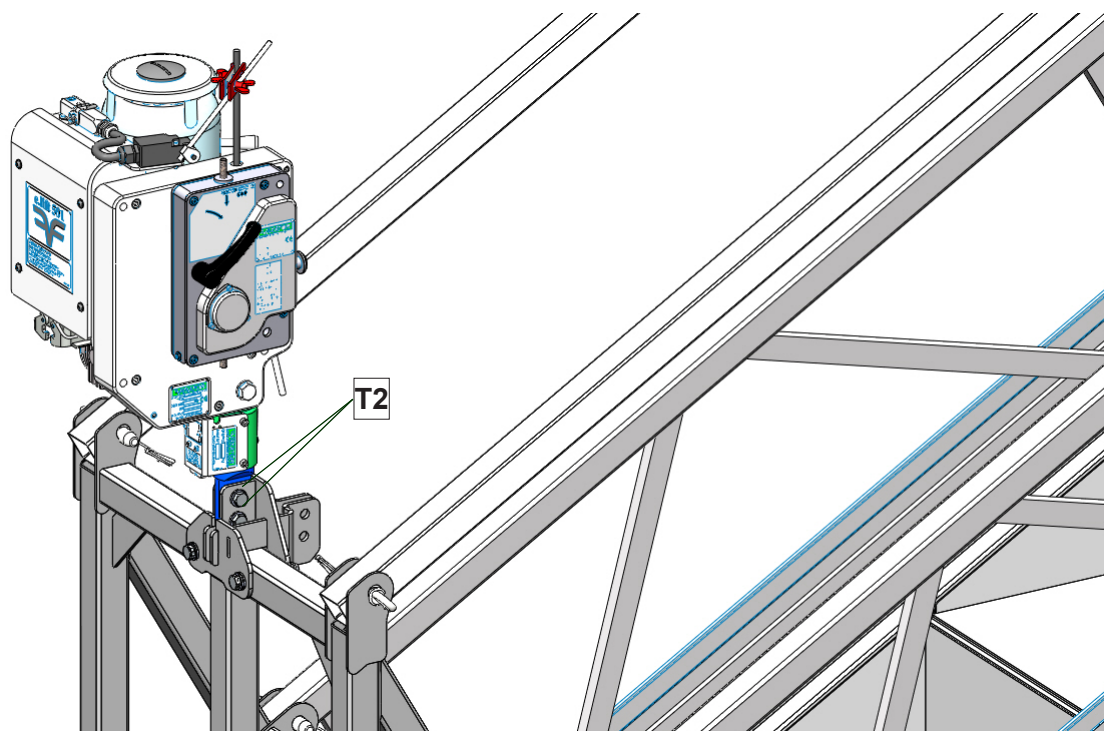

External position

Fix the cabinet support (15) on the 2m handrail (12) as shown in the image, using 4 T5 screws.

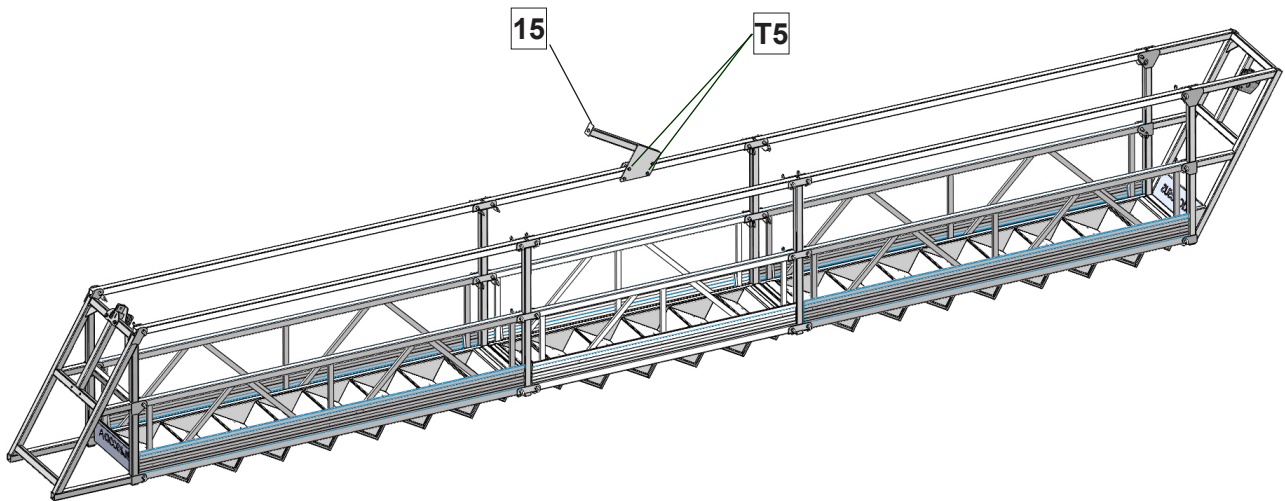

Place the electrical cabinet (3) in position.

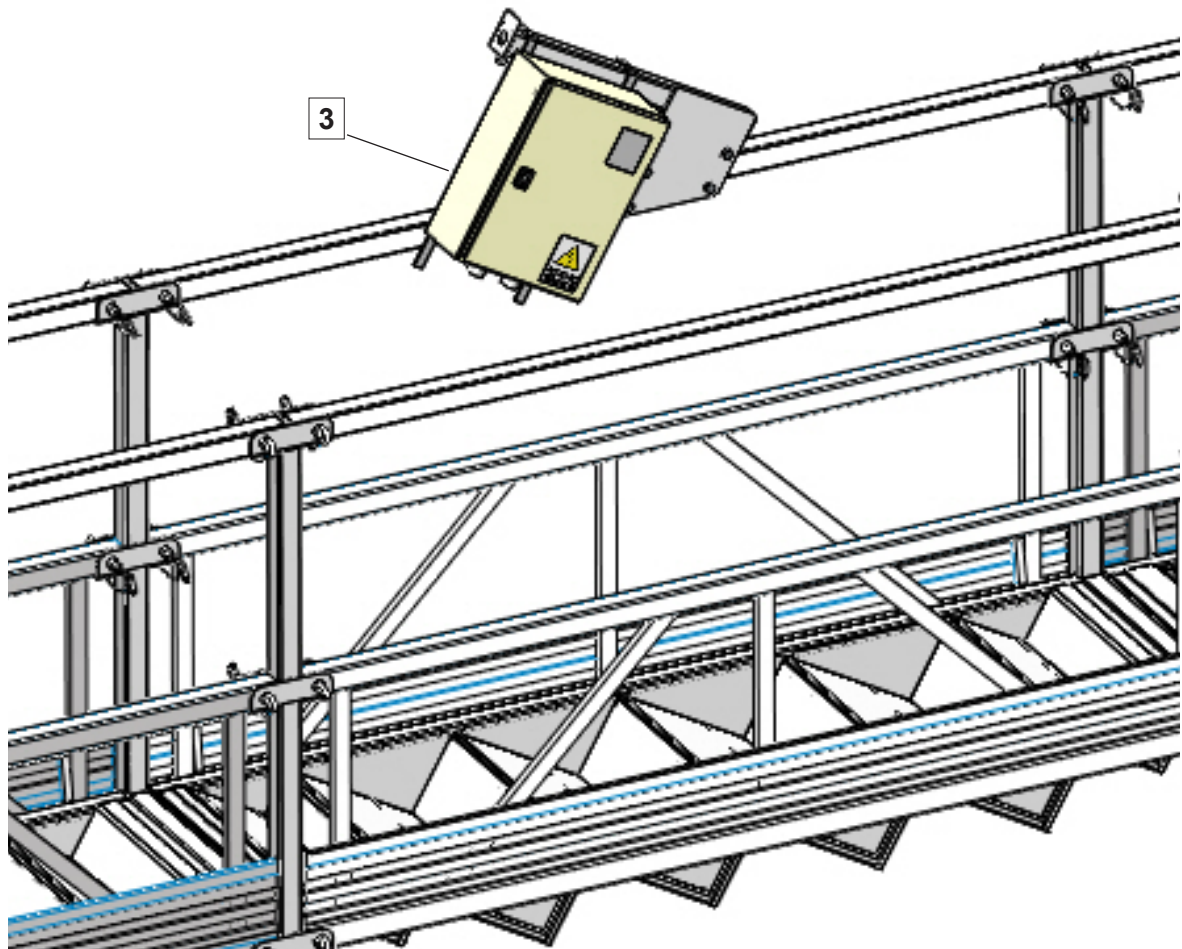

The platform with carrier end panels is fully assembled.

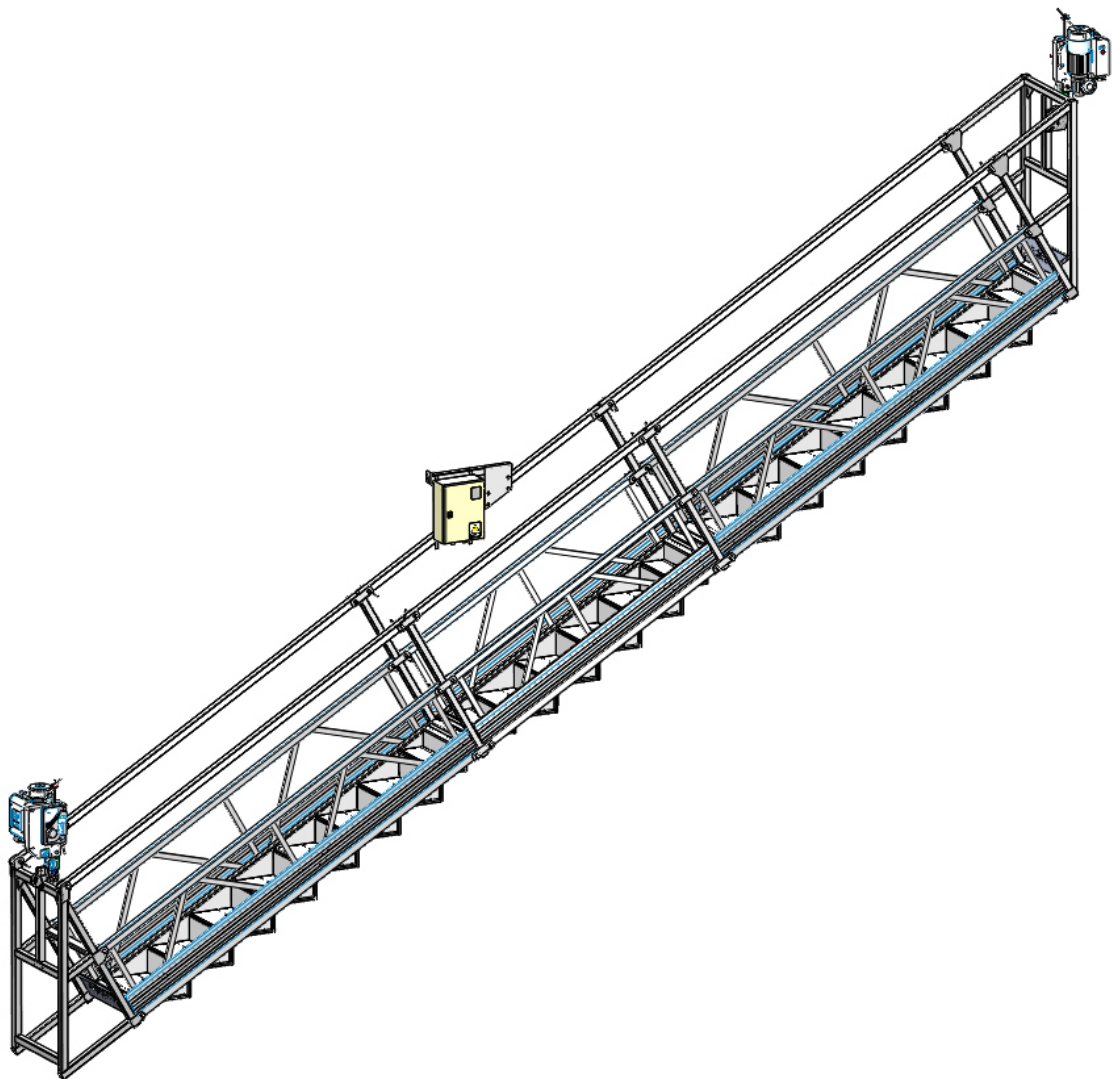
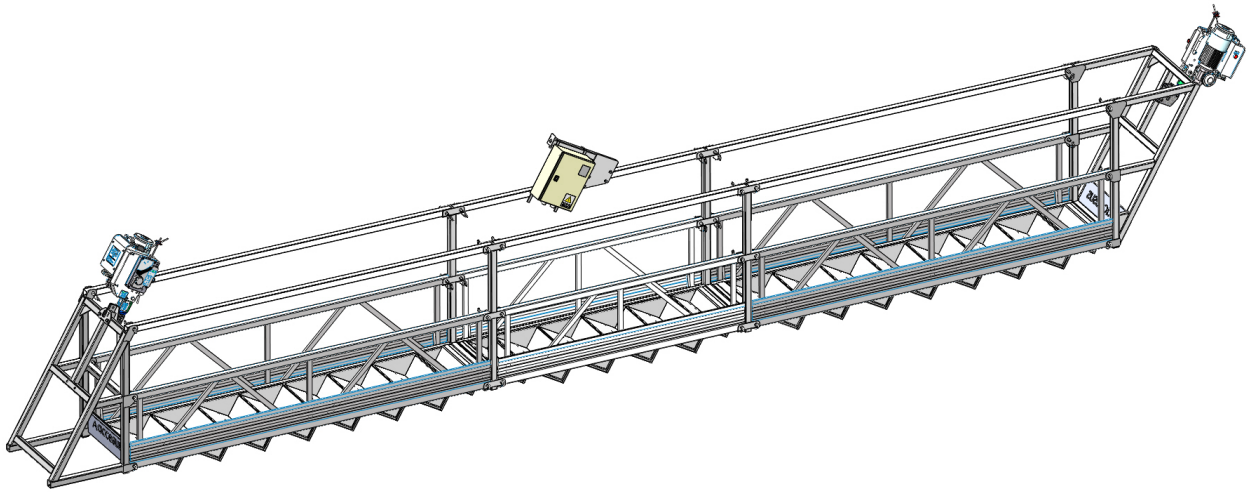

## 6.4-Electric components

In the case of the platform equipped with two electric elevators e.lift501 and its corresponding electrical cabinet.

Ensure that the power supply connector is compatible with the electric cabinet.

- Three-phase 400 V 50 Hz
- Mono-phase 230 V 50 Hz

- The power supply must be protected, before the connector, with a 16A differential circuit breaker 30 mA.
- The cable's gauge between the floor and the platform must be compatible with the power of the devices and the cable's length. See table:

Hose length	50 m	100 m	200 m
Three-phase 380-400V	2.5	2.5	2.5
Three-phase 230V	2.5	2.5	4
Monophase	2.5	4	6
Minimum cross-section in mm <sup>2</sup> (per wire) for 2 e.lift501			

- Fix the electric cabinet on the handrail.

• Connect the power supply cable from the electric cabinet to the power supply hose by means of a CEE 16A connector. The hose must be fixed to the platform with a pin. For superior heights to 100 m you have to verify the efforts admitted by the cable.

• Connect the e.lift501 hoist to the electric cabinet and check the correct running of the device. Before a working day is obligatory to check the stop emergency.

• The device is protected with a system of phase control relay. If this device doesn't work try to reverse the phases with a screwdriver. See attached photo.

• Earth wire is done through the power supply line. The earthing function must be checked (check the protective cable and isolation). Optionally additional measures will be necessary.

• If necessary, a generator with a power equivalent to three times the rated power of the winch (nominal power of the generator [kVA] = number of winches x nominal capacity of the winches [kW] x 3) can be used. The generator must be grounded by the operator. The earthing function must be checked (check the isolation protection).

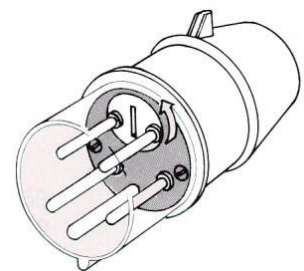



### 6.5-Introduction of the wire ropes in the platform



**DANGER!**

**Hurts for wire ropes manipulation.**

Danger of cuts and scratches.

**Risk of wounds and injuries due to fall of objects, fall from different level and / or breaks.**

Danger of death due to fall of objects, fall from different level and / or breaks.

- Before the assembly of the wire ropes ensure that the supporting point have enough capacity to support the efforts of the suspended loads, described in section 6.1 of this manual.
- Use suitable PPE's: harness, protective gloves, safety boots, protective helmet, etc.
- Only use wire ropes specified by the manufactures.
- Ensure that the wire rope's diameter is the same as indicated at the e.lif501 and securichute600 labels.
- Ensure that the wire rope's length is enough for the height.
- Ensure that the wire rope's tip is in good condition.
- Avoid the loop's formation at the wire ropes when manipulating.
- Place the platform in dead weight under the suspension.

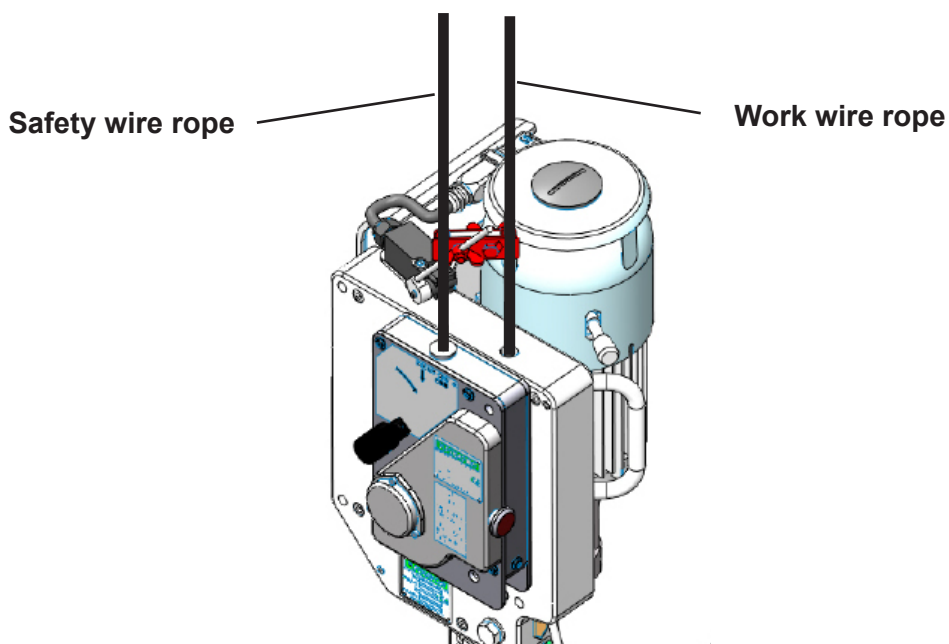

### 6.5.1-Introduction of the work wire rope

- 1- Insert the tip of the cable into the elevator until it stops.
- 2- Turn the electric cabinet selector to select one or another elevator.
- 3- Press "UP" button and continue pushing the wire rope until the hoist tows the wire rope for itself.
- 4- Pass the wire rope where indicated in the image in these two cases of elevator placement
- 5- Press "UP" button until the wire rope gets slightly tight.

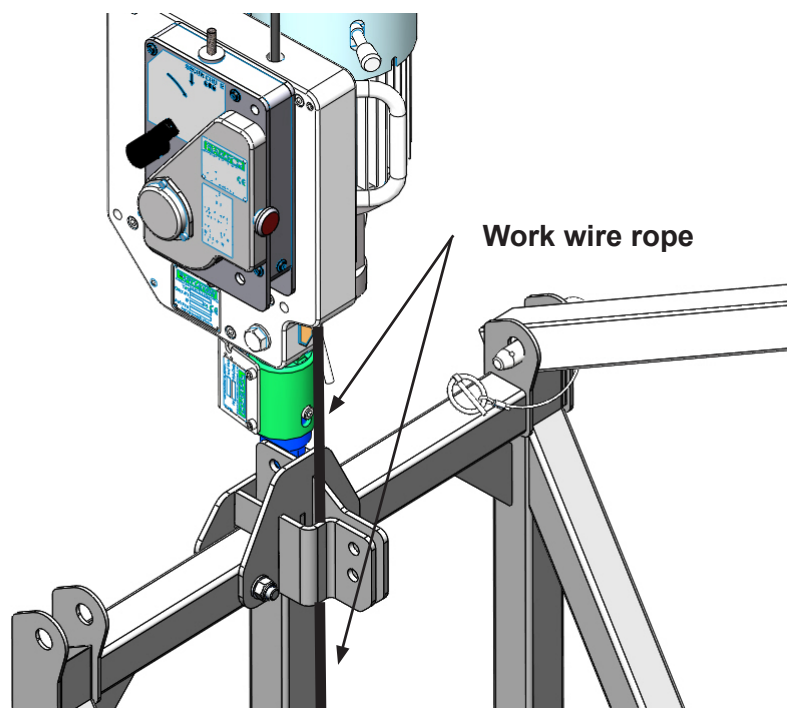
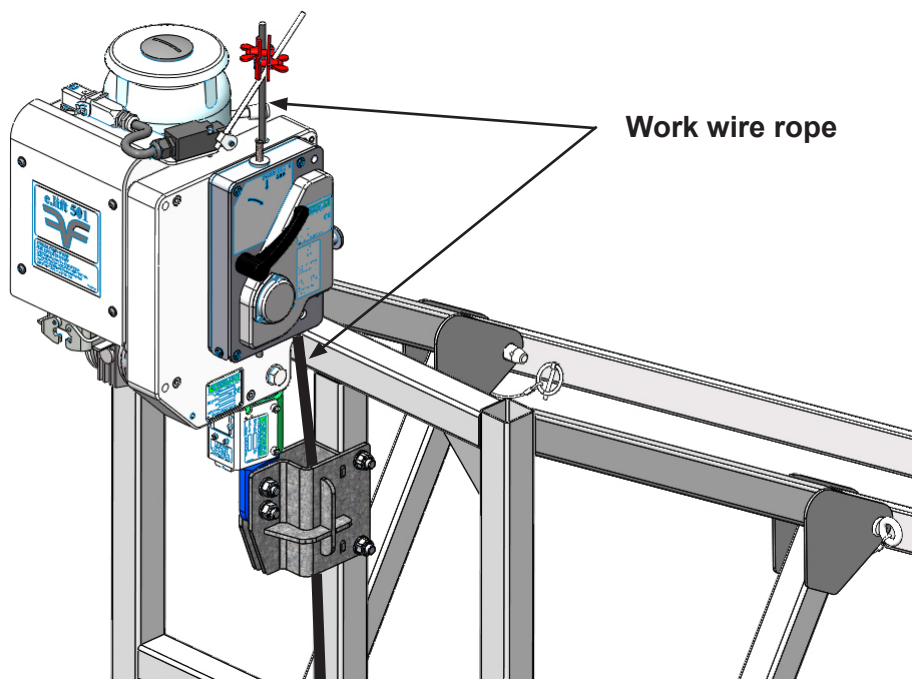

6.5.2-Introduction of the safety wire rope

1- Before to seep the secondary wire rope into the pulleys you have to verify that is not rolled with the suspension wire rope.



**IMPORTANT!**

<p><b>Excessive wear in over-speed detection mechanisms of Securichute600 device.</b></p>	<p>Danger of death due to fall of objects, fall from different level and / or breaks.</p>
	<p>-Block the stop emergency button of the securichute600 pressing and turning it.</p>

- 2- Block the stop emergency button, pressing and turning it.
- 3- Push down the reset handle.
- 4- Introduce the wire rope's tip into the securichute600 and slightly tight it.
- 5- Unblock the stop emergency button, returning it.

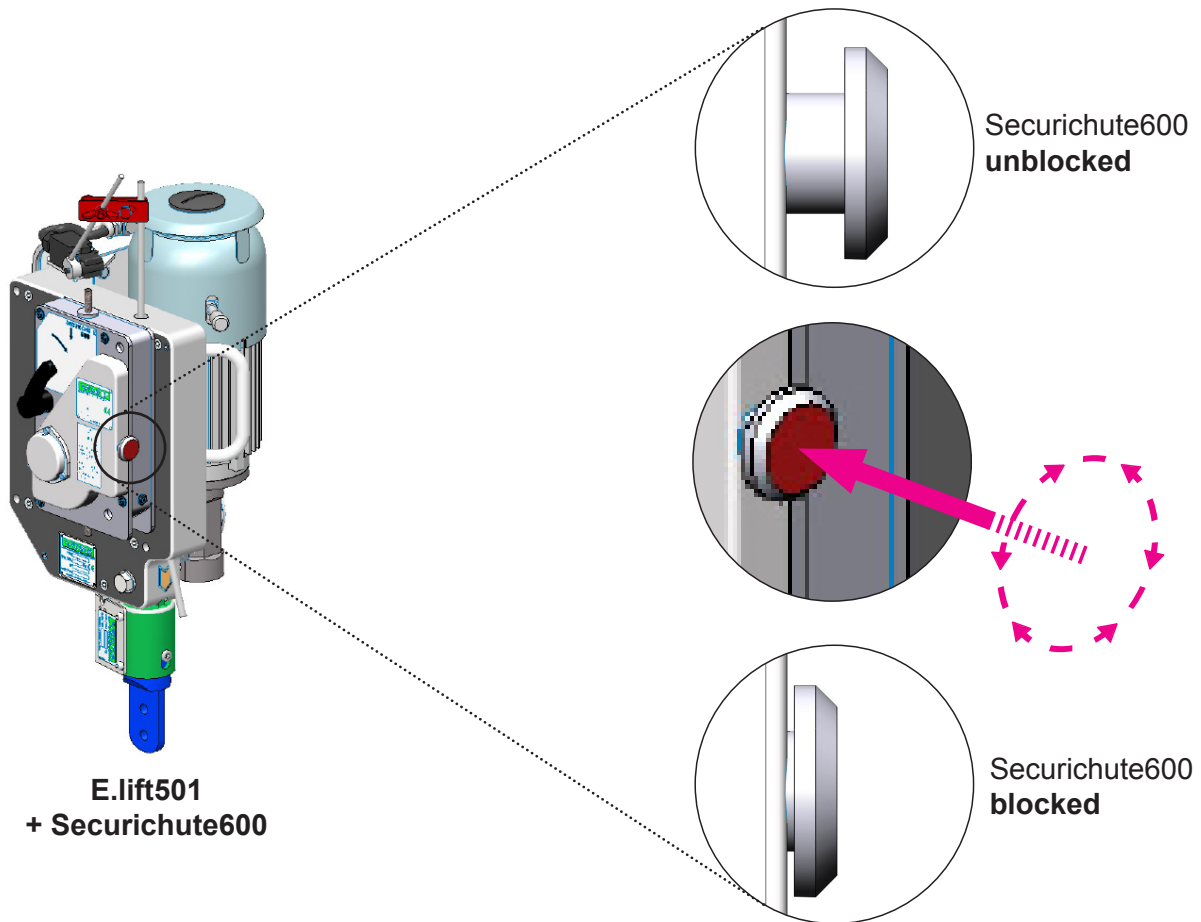

6- Attach a Grip'cable clamp and a counterweight on the safety wire rope, about 20cm from the ground.

7-Carefully roll in the reels, 1 for each cable, the excess cable that is not used

8- To remove the wire rope, block the emergency button by pressing and turning it, keep the reset lever fully and slowly pull the cable upwards after having removed the counterweight.

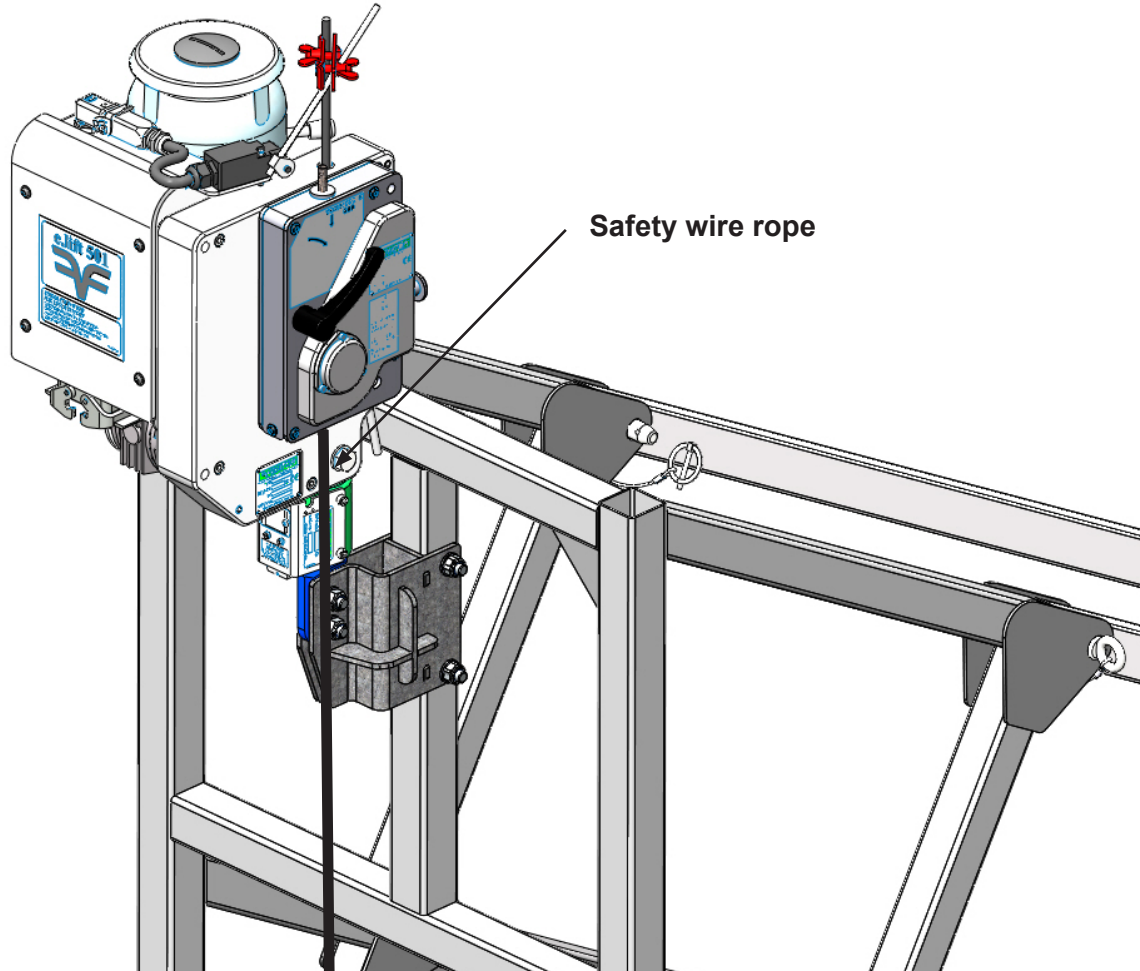

### 6.6.2.1-Installation of counterweights

Lift the platform 50 cm, install the the 20 kg counterweight on the safety wire rope with the help of the Grip'cable clamp.

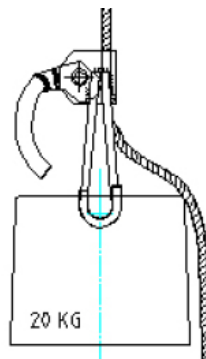



**DANGER!**

<p><b>Danger of death due to fall of objects, fall from different level and / or breaks.</b></p>	<p>Danger of death due to fall of objects, fall from different level and / or breaks.</p>
	<ul style="list-style-type: none"> <li>-Do not stay under suspended loads.</li> <li>-If necessary, block the danger zone.</li> </ul>

When performing the following tests, the equipment must be loaded with the maximum load limit, in order to be able to check the operation of the safety devices.

6.6.2- Running test for electric elevator e.lift501

6.6.2.1- Check the operation of the electric elevation system

Check the service brake

- Connect the lift upwards until the wire rope is tightened.
- Raise the load approximately 1m
- Stop the movement.
- Move it down.
- Stop de movement.

The stopping distance must not exceed 10cm. The elevator must hold the load.

- Download the load and loosen the wire rope.
- Stop the elevator.

The elevator must hold the wire rope.

If the lift does not hold the load, the wire rope and / or the stopping distance is greater than 10cm, have the elevator checked and repaired by ACCESUS or an authorized workshop by ACCESUS.

Check the operation of the detectors

**A-** Check the UPPER limit switch, see section 7.6.

- Shoot the limit switch manually.
- The upward movement must be stopped, the winch must hold the load and the descent must be possible.

**B-** Check the phase control relay, see section 7.7

If the phase control relay does not disconnect the drive when it is first connected and the drive is moved in the correct direction with the UP button, everything is correct. If the direction is not correct or the phase control relay disconnects the drive, use the phase inverter, see 7.7.

Check operation emergency stop

- Connect the lift upwards until the wire rope is tightened.
- Press EMERGENCY STOP

The power supply to the motor must be switched off immediately. The elevator must hold the wire rope.

6.6.2.2- Check the operation of the securichute600 fall arrester (see section 11.4)

Verify that the securichute600 ensures the attachment to the cable.

- Press the emergency button of the securichute600. The jaws must close automatically and it must be impossible to pull the wire rope upwards manually.

-Rearm the securichute600 by actuating the reset lever. The safety wire rope must be able to move freely through the securichute.

**End of the check:** Record the result of the checks in the log book..

## 7-Safety devices

In order to guarantee a correct working order of the TSP and safety for the workers, the platform with manual hoists m.lift400 has the follow safety devices:

### 7.1-Integrated safety devices in electric hoist e.lift501

a) A brake system works in case of absence of electric supply or when the worker does not press the UP or DOWN buttons.

b) The electromechanical overload sensor stops the electric supply in case of overload at the platform or in case of set-back during the ascend.

The overload is indicated through the illuminated pushbutton located at the electric hoist., optionally by the acoustic alarm (H1) of the electrical cabinet.

c) The upper limit switch sensor stops the ascent when the bolt touches the upper limit.

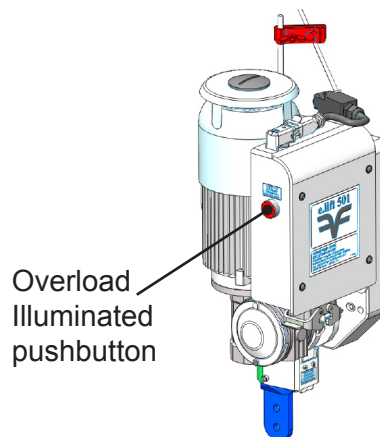

E.lift501 hoist

### 7.2-Integrated safety devices in electric cabinet

In case of emergency the platform’s movement can be stopped immediately pressing the “STOP EMERGENCY” button (S0) located at the electric cabinet.

When the emergency has disappeared spin the button in arrows direction, press the GREEN start button (S1). Finally use the UP (S3) or DOWN (S4) buttons.

Inclination sensor stops the movement in case of excessive inclination.

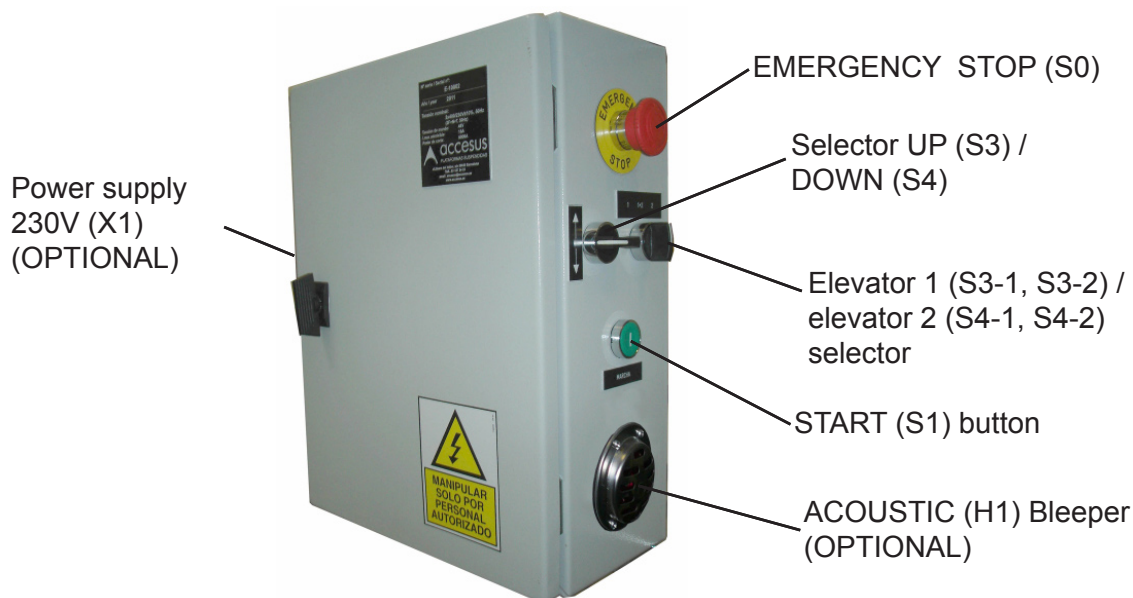

Electric cabinet



### 7.3-Fall arrest device system securichite600

When the platform is running the secondary wire rope pass freely into the gags.

If the safety wire rope is blocked it might be due to the following reasons:

- a) break of the work wire rope,
- b) elevator breakdown,
- c) any problem with the hoist that causes an increase of the velocity,
- d) a crash,
- e) overtilting of the platform,
- f) STOP EMERGENCY button is blocked,
- g) gags not reset.

For a) and b) cases it's necessary to do a particular emergency operation.

For c), d), e), f) and g) cases the worker must tense the suspension wire rope using the e.lift501 hoist. After that go up some centimeters, unblock the STOP EMERGENCY button and push the RESET handle of the securichute600 fall arrest device until his open position.

If the powered hoist glides, the worker can stop the platform pushing the STOP EMERGENCY button of the securichute600 fall arrest device.

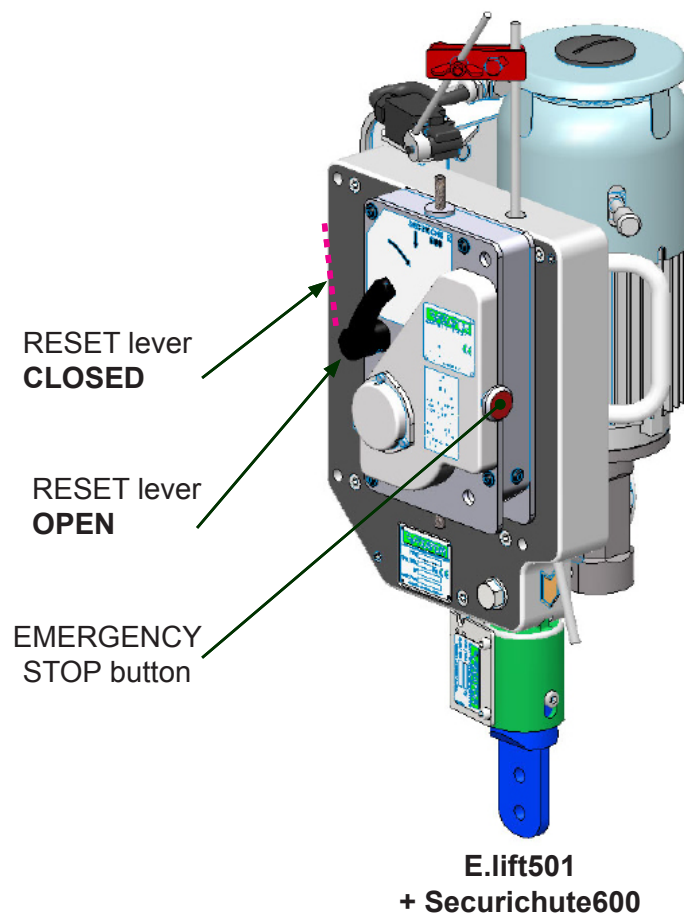



### 7.4-Overload safety system in e.lift501

The overload safety device integrated at the hoist stops completely the platform in this cases:

- a) Overload or incorrect load distribution at the platform,
- b) The platform has an obstacle during the ascent.

An acoustic bleeper, placed at the electric cabinet, reports this overload.

If the platform has overload it's necessary to remove the load over the platform or the obstacle. After that it's necessary to press the overload illuminated pushbutton and START for a restart of the platform.

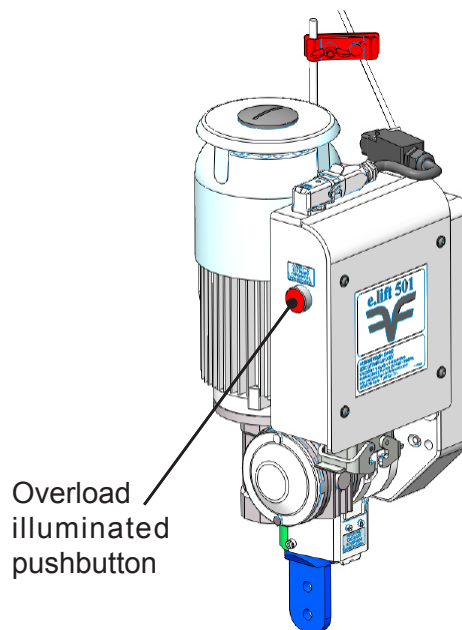

E.lift501 hoist

**i** NOTE

If it is necessary to adjust the overload limit, request the procedure from ACCESUS by one of the means indicated in section 1

### 7.5-Upper and final limit switch in e.lift501

The ascent of the platform stops when the upper limit switch touches the end fixed disk at the wire ropes.

The descent continues being possible.

In case of error, this device has a second contact that stops all the platform's movements.

The upper limit switch must be installed on safety wire ropes, 20-30cm under height of the wire hook.

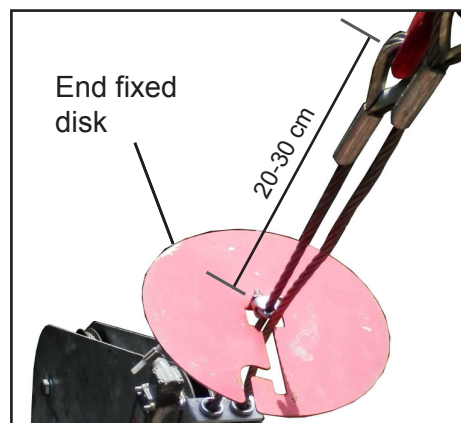

### 7.6-Phase controller

The three-phase equipments has a device which controls the direction of the phases. It is placed at the electric cabinet. This phase controller stops the power supply in case of an erroneous connection.

It's possible to invert the phases at the CEE connector by rotating 180° with a screwdriver.

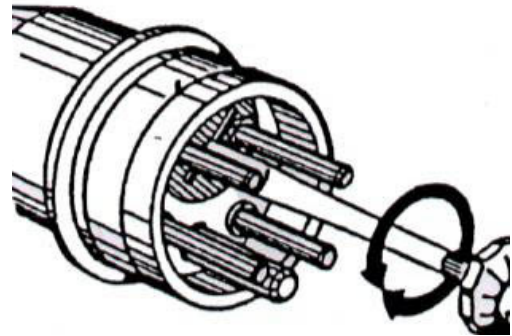

### 7.7-Emergency descent in e.lift501

The powered hoists are equipped with a manual system that allows the descent of the platforms in case of no power supply.

The lever of emergency descent allows to descend with a controlled velocity in every moment.

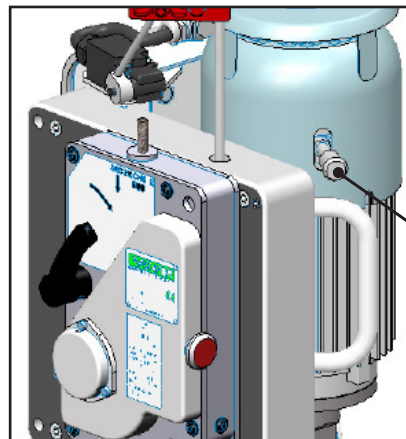

EMERGENCY DESCENT lever

**E.lift501  
+ Securichute600**

### 7.8-Acoustic bleeper (Optional).

The acoustic bleeper (H1) of the electric cabinet it can be use for a S.O.S. message or for advert to other workers. This sign runs when the EMERGENCY STOP button is blocked and acting simultaneously on the UP (S3) or DOWN (S4) selector.

## 8-Operating the platform

### 8.1-Preliminary checks

- a) Use only wire ropes specified by ACCESUS. It must be replaced if there are any damages such as described at section 11.2.1.
- b) Verify the correct working order of hoist, brake engine, securichute, limit switch, overload, stop emergency, acoustic bleeper, etc.
- c) Verify the safety of the suspensions and ensure that all the components and counterweights are there. Control specially the hooks and the wire rope's fixation.
- d) Ensure that the suspensions are in dead weight with the platform.
- e) Ensure that the load over the platform not exceeds the weight load limit including snow, ice, materials...
- f) **To cover risks arising from misuse, the use of personal protective equipment (PPE) is mandatory for operators:**



**DANGER!**

<b>Danger of death due to fall of objects, fall from different level and / or breaks.</b>	Danger of death due to fall of objects, fall from different level and/or breaks.
	- Can be anchored <b>ONLY</b> by one of the following two systems, <b>NEVER</b> both at the same time.

#### OPTION 1:

Use of EN361 harnesses and fall arresters EN352-2 with the corresponding lifeline with a length equal to or greater than the cables.

The lifeline, to which the operator will join by means of the fall arrester, must always be anchored to a resistant element independent of the platform and the suspension.

#### OPTION 2:

Use of harnesses EN361 and anchoring sling (EN354) with absorber (EN355) anchored to one of the anchor points (EN795) provided by the platform (availability of the anchor point EN795 depends on the model and configuration of the platform)..

In addition all operators must be equipped with all necessary PPE:

- harness,
- 1.5m anchoring cable with absorber,
- safety gloves,
- security boots,
- helmet with barbell,
- suitable work clothes.

**Anchor points**

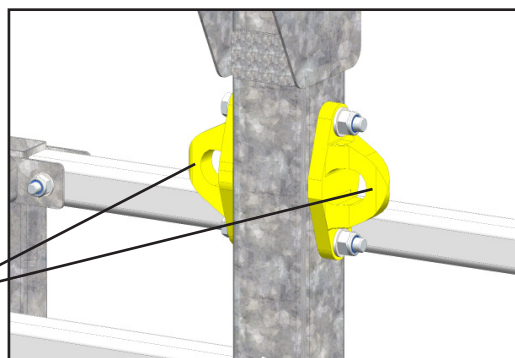

g) It is recommended to sign correctly the floor's area susceptible of objects fall (tools, materials...) used at the platform and under the guide rope as well. This recommendation becomes mandatory when the public can access the area.

h) The equipment is intended to be used in luminous areas (natural or artificial). In case of use artificial illumination, the worker must dispose with enough light.

i) Ensure that the temperature of the environment is over  $-10^{\circ}\text{C}$  and under  $+55^{\circ}\text{C}$ .

j) Don't work in case of hard wind (superior to 50 km/h) or storm.

k) When the work is finished, the responsible of the work must place the platform out of service and switch off the power supply.

**It is forbidden to:**

a) Use the platform with no safety wire rope and no securichute600 fall arrest device.

b) Deactivate the safety devices (overload, upper limit switch...)

c) Overload the platform.

d) Loads over the people.

e) Descend the platform manually with the brake of the e.lift501 hoist when the powered descent is possible.

**In some countries of the European Union is obligatory an exam of the commissioning, before the works, by an authorized organism.**

## 8.2-Rated capacity

### IMPORTANT!

The loads will be calculated as follow:

– The first and second person is calculated with a weight of 80 kg + 40 kg for tools and materials. The following people are calculated with 80 kg.

The load must be distributed uniformly all over the platform.

### LOAD CAPACITY

Elevator	Platform length (m)	8
e.lift® 501	Weight load capacity (kg)	320
	Number of people	3
	Dead weight (kg)	550

## 8.3-Loading / unloading areas

Whenever possible, loading and / or unloading at the lower level.

To carry out the **loading and / or unloading on a different level than the lower one**, the following guidelines must be followed:

-The operator must have the approval of the safety responsible person of the work to carry out the unloading maneuver on a different level than the lower one.

-There must be a written document for a loading procedure at a different level than the lower one. The procedure should include eventual rescue.

-The operator must be equipped with suitable PPE's for the maneuver to be carried out: Harness, double anchor sling, helmet with barbell, and all the necessary PPE's.

-The operator must be at all times anchored to an anchorage point enough resistant and in accordance with the standard EN795, during the unloading maneuver and until it is located in a safe area protected by handrail.

-It is forbidden to carry out this maneuver alone.

### 8.4-Electric controls

Up and down platform movements are controlled from the electric cabinet placed in the middle of the platform.

In case of an error, wait until that movement finish completely before effectuate other order. The buttons has an immediate action.

**Avoid maneuvers with consecutive impulses at the control.**

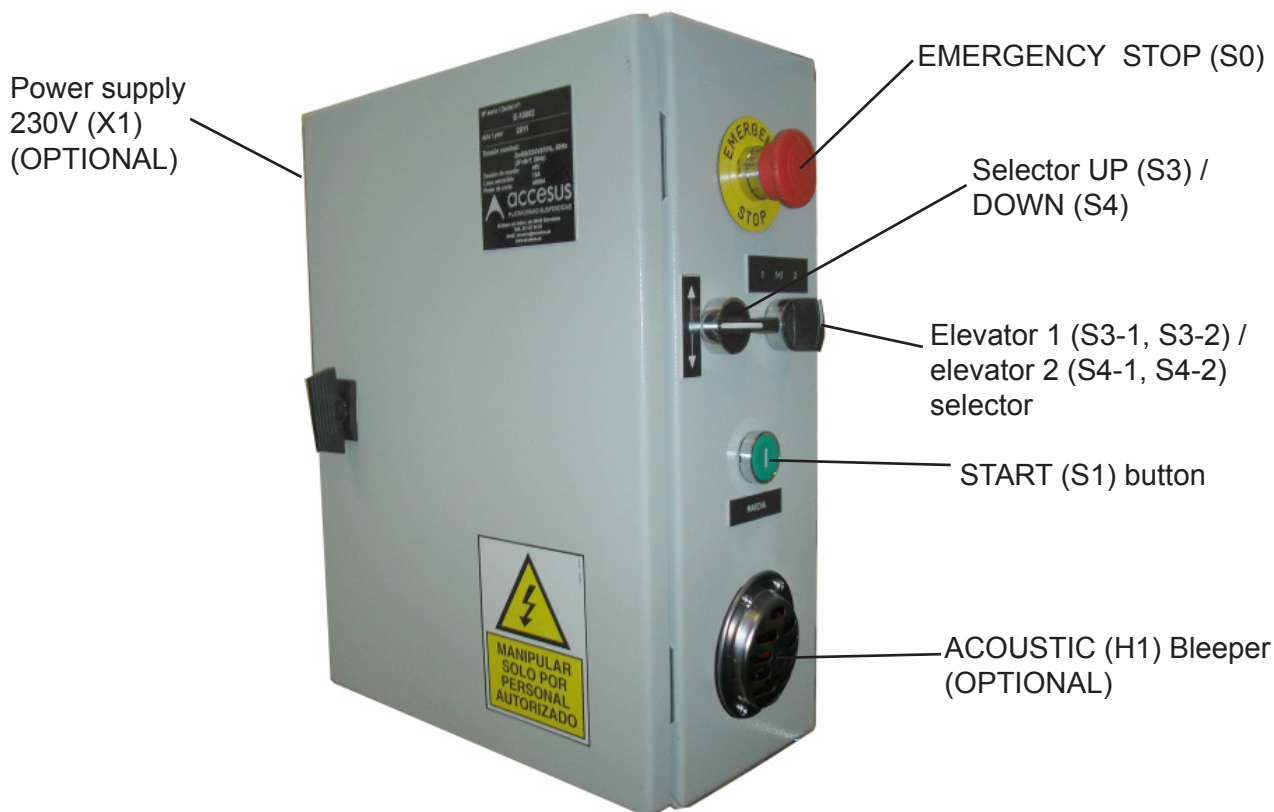

In case of emergency, the movement of the platform can be immediately stopped by pressing the “emergency stop” (S0) in the electrical cabinet.

Once the cause of the emergency has disappeared or eliminated, turn the button in the direction indicated by the arrows, press the GREEN start button (S1). Finally use the UP (S3) or DOWN (S4) selector.

The inclination detector stops movement in case of excessive inclination:

- A contact that cuts the feeding of the elevator in upper position. The operator keeps pressing UP: The elevator that had stopped automatically (the upper one), will continue its movement as soon as the platform returns to recover the horizontal position.

- Similarly in descent it cuts the feeding of the lowest elevator. The operator continuous pressing DOWN: The elevator that had stopped automatically, will continue its movement as soon as the platform returns to recover the horizontal position.

## 8.5-No power emergency descent

**It's forbidden to descend the platform using the e.lift501 hoist brake when the electric descent is possible**

The powered hoists are equipped with a manual descent system in case of no power supply:

- a) Stop the power supply disconnecting the socket.
- b) Raise the emergency down lever located at the rear side of the hoist in order to open the brake service. The platform descends by his dead weight and his velocity is limited and controlled automatically.
- c) If the platform don't descend, an initial impulse must be given turning clockwise the maneuver's flywheel (1) situated in the axis of the engine after the extraction of the plastic cap (2).
- d) The platform stops when the brake's handle is released.
- e) When the platform is on the ground, remove the flywheel and place it into the slot. Place the plastic cap over the engine.

**In case of overload it is forbidden the no power emergency descent.**

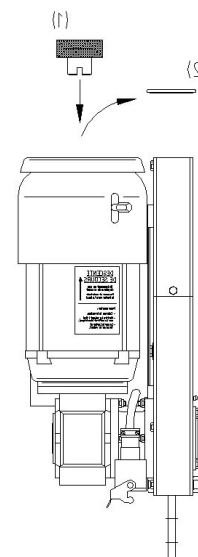



## 8.6-Action in case of the fall arrest locking

In case of securichute600 fall arrest block, act as follows

### If there are power supply.

Press "UP" at the electric cabinet until the work wire rope get tensioned. Open the reset lever on the securichute600 fall arrest device. Now you can continue working.

### If there aren't power supply.

Extract the plastic cap (2). Turn clockwise the maneuver flywheel (1) placed in the engine's axis, at the same time open the engine's brake, until the work wire rope get tensioned. Open the reset lever of the securichute600 fall arrest device. Now you can continue working.

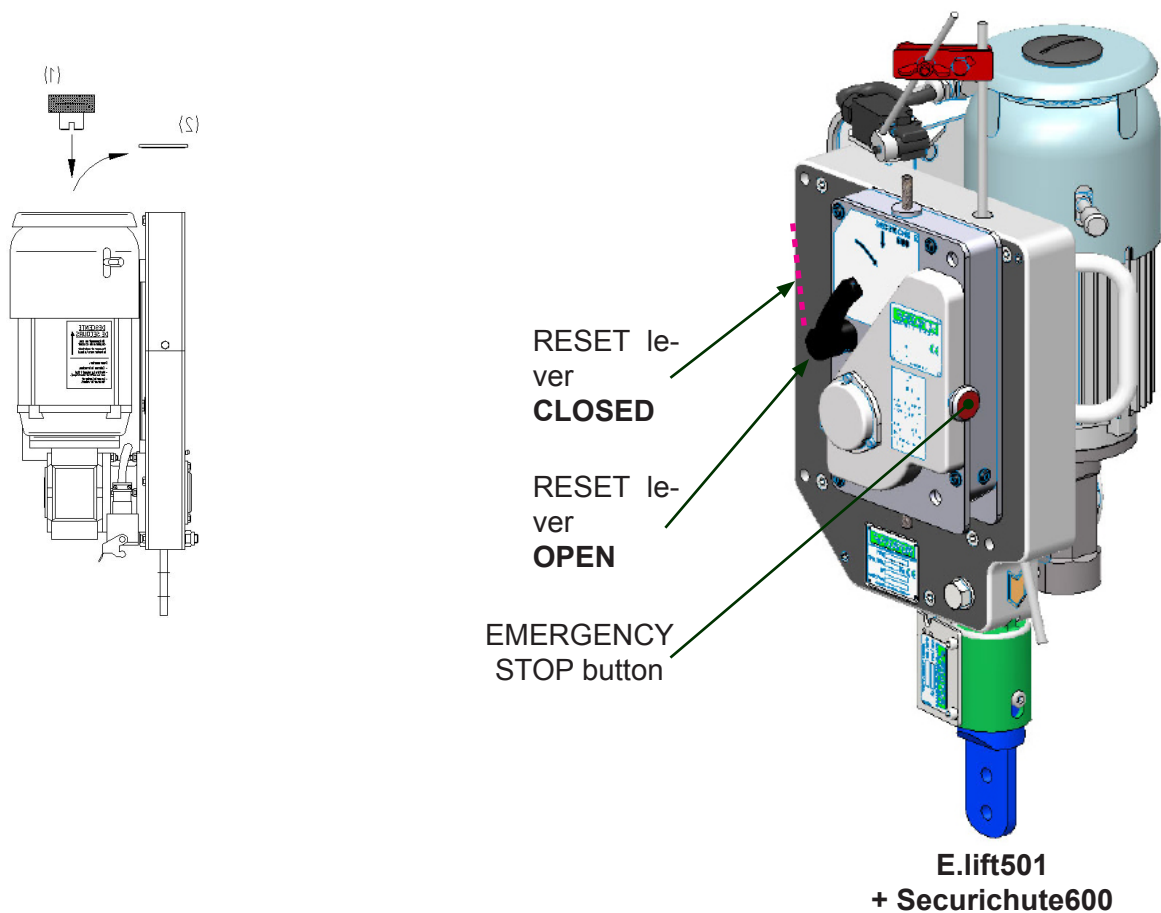

## 8.7-Request for help with the acoustic bleeper (optional)

In case of emergency or request for help.

The ACOUSTIC (H1) bleeper placed in the electric cabinet can be used as an S.O.S. distress signal or to advert other workers. This sign is activated with the EMERGENCY STOP button (SO) blocked and pushing START (S1) button.

**S.O.S. is the most used distress signal. Consists of a continuous sequence of three-dots / three-dashes / three-dots, all run together without letter spacing.**



### 8.8-Platform leveling



**DANGER!**

<b>Risk of wounds and injuries due to fall of objects, fall from different level and / or breaks.</b>	Danger of courts and scratches.
	Danger of death due to fall of objects, fall from different level and / or breaks. -Do not stay under suspended loads. -If necessary, block the danger zone. -Before to disassemble the platform and during the maneuver, ensure that nobody is on the danger's area. -Use adequated PPE's: harness, protection gloves, safety boots, helmet, etc. -Use intercomunicators in order to coordinate maneuvers between the workers

To regulate the platform with the angle required for its location, the equipment must be lifted in an unbalanced manner, starting with the elevator located in the upper end of the lyre. The upper end panel (5) must remain elevated with respect to the lower one (4), until the steps are able to walk through them. The objective angle is 30° respect to the horizontal.

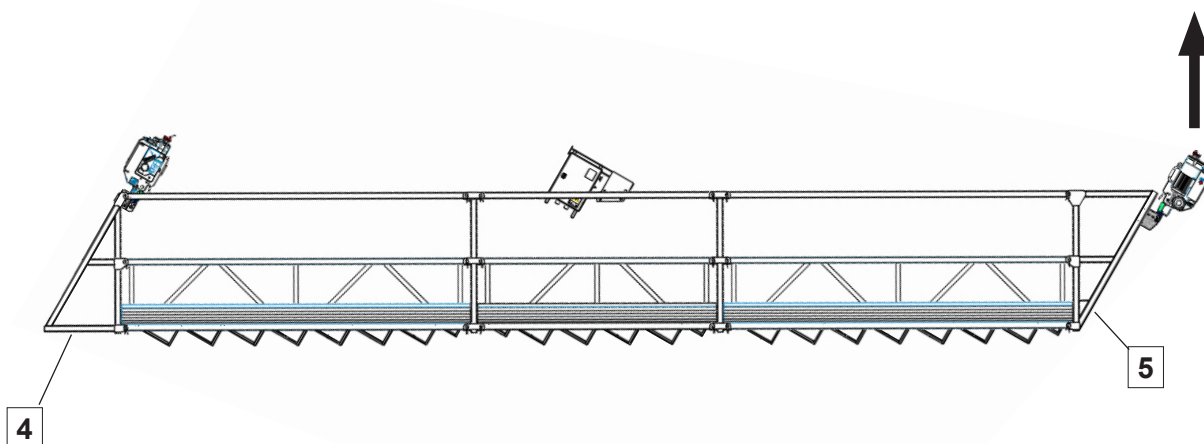

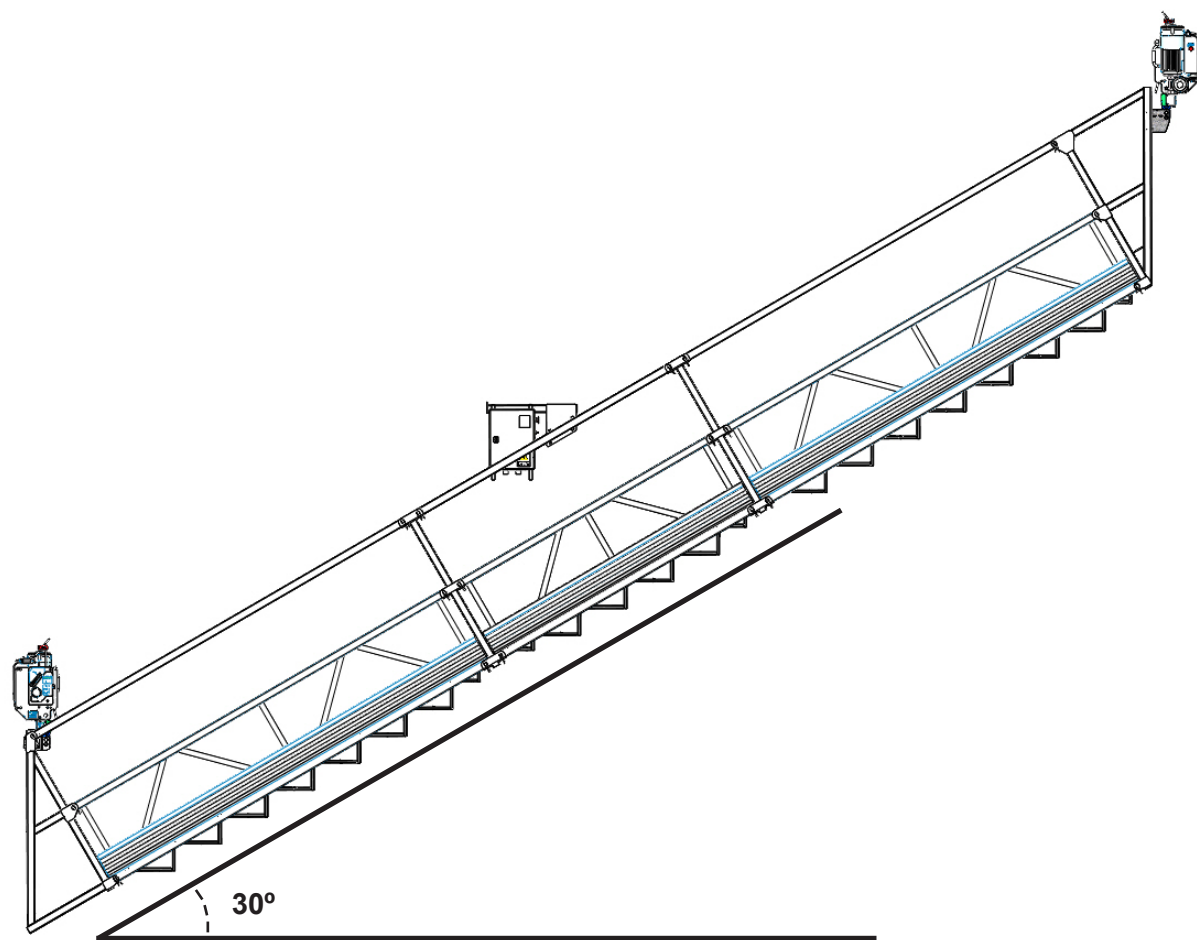

## 8.9-Moving the platform horizontally

For the displacement of the platform two operators are needed, one at the level of suspension structure and another on the platform. When working at the level of the suspension they must be equipped with a harness that is anchored to a anchor point with sufficiently capacity load.

1-Place the platform about 30cm above ground level.

2-Remove the counterweights from the safety wire ropes.

3-Leave the safety wire ropes loose enough.

4-Support the platform on the ground and leave the work wire ropes loose. **Never remove the wire ropes from the suspension structure.**

5-Move the platform until is in the vertical of the suspensions.

**6-Avoid placing the platform by means of elevators;** It could cause a dangerous swaying or a deterioration of the material.

7-Tension the work wire ropes by pressing the UP button.

8-Lift the platform about 30cm.

9-Tension the safety wire ropes by hand and hook the counterweights to each safety wire rope. Carefully wind the unused length of wire rope in the winders.

### 8.10-Removing the wire ropes



**DANGER!**

<p><b>Hurts for wire ropes manipulation.</b></p> <p><b>Risk of wounds and injuries due to fall of objects, fall from different level and / or breaks.</b></p>	<p>Danger of courts and scratches.</p> <p>Danger of death due to fall of objects, fall from different level and / or breaks.</p> <p>-Before to remove the wire ropes and during the maneuver, ensure that nobody is on the danger's area.</p> <p>-Use adequate PPE's: harness, protection gloves, safety boots, helmet, etc.</p> <p>-Avoid the creation of loops when manipulating the wire ropes.</p> <p>-It must be communication in order to coordinate the maneuvers between the workers at ground and the workers at the roof beam.</p>
---	--

For removing the wire ropes are necessary 2 people, 1 at the at the suspension area or roof beam and 1 at the base of the support zone of the platform.

- a) Get down the platform until the ground and loose the wire ropes.
- b) Extract the suspension wire rope from the hoist pressing the “descend” button, or manually.
- c) Extract the safety wire rope from the fall arrest device.
- d) Move the roof beams or suspension towards inside the roof of the building.
- e) At the ground start to wind up correctly the first section of the work and safety wire ropes cables on their winders
- f) The operator located on the roof, will disengage one per one the wire ropes from the suspensions and with a rope of appropriate length will leaving them down to the ground. **Do not drop the wire ropes in free fall.**
- g) The operator on the platform level will correctly wind up the work and safety wire ropes into their winders.

### 8.11-Dismantling the platform



**DANGER!**

**Hurts for wire ropes manipulation.**  
**Risk of wounds and injuries due to fall of objects, fall from different level and / or breaks.**

Danger of cuts and scratches.  
 Danger of death due to fall of objects, fall from different level and / or breaks.

- Before to remove the wire ropes and during the maneuver, ensure that nobody is on the danger's area.
- Use adequate PPE's: harness, protection gloves, safety boots, helmet, etc.
- Avoid the creation of loops when manipulating the wire ropes.
- It must be communication in order to coordinate the maneuvers between the workers at ground and the workers at the roof beam
- Use intercoms for the coordination of maneuvers between operators.

To dismount the platform follow inversely the steps described at section 6.3.

## 9-Residual risks not covered by the design of the TSP

- The platform is not equipped with an anti-collision device which stops automatically the ascent or descent in case of obstacle.  
The worker must verify visually if there are any obstacles in the trajectory.



**DANGER!**

- SECURICHUTE600 fall arrest device is not equipped with a device which stops automatically the ascent or descent in case of block.

The worker must verify visually if the SECURICHUTE600 gets blocked and realize the maneuvers described to unblock.

If the SECURICHUTE600 is blocked, the platform can ascend normally but can not descend cause it will be suspended by the safety wire rope. If this case is given see the section 8.8 described in this manual.

- The noise level generated by the e.lift®501 powered hoist has a maximum of 70dB (A) from a distance of 1m.
- Don't work with wind superior to 50 km/h (14 m/sec).
- It's forbidden to work in case of strong wind or storm.

## 10-Troubleshooting



**DANGER!**

<b>Risk of wounds injuries or death due to fall of objects, fall from different level, breaks and/or electric-contact.</b>	Danger of death due to fall of objects, fall from different level and / or breaks. Danger of death by electric contact.
	<ul style="list-style-type: none"> <li>- Stop the works immediately..</li> <li>- Identify the cause and solution the breakdown.</li> <li>- Before the works disconnect the power supply plug (CEE) of the platform. The worker must verify in every moment that the plug is disconnected.</li> </ul>

These are the instructions to identify and repair the breakdowns for platforms equipped with e.lift501 hoist.

Break-down	Probable reason	Solution
The motor does not rotate	<ul style="list-style-type: none"> <li>-The brake without power is disconnected or out of order.</li> <li>-The temperature sensor is activated.</li> <li>-The overload is activated.</li> <li>-The motor has a mechanical fault.</li> <li>-The contactor in the hoist is out of order or disconnected.</li> <li>-The general contactor of the control box is out of order or disconnected.</li> <li>-The limit switch is activated.</li> <li>-Fault in the control circuit.</li> <li>-Fault in the power circuit.</li> <li>-Power supply fault.</li> <li>-Humidity "jams" the brake on the motor.</li> </ul>	<ul style="list-style-type: none"> <li>-Reconnect the brake or change it.</li> <li>-Wait for a drop in temperature.</li> <li>-Reduce the load.</li> <li>-Check the motor.</li> <li>-Reconnect or replace it.</li> <li>-Reconnect or replace it.</li> <li>-Have a competent person check it.</li> <li>-Check.</li> <li>-Have a competent person check it.</li> <li>- "Tap" gently on the motor spindle while-pressing on the control buttons.</li> </ul>
The hoist does not rise	<ul style="list-style-type: none"> <li>-The grooved pulley is worn or dirty.</li> <li>-The starting condenser and the centrifugal coupler are disconnected or out of order (only for a single phase hoist)</li> <li>-The temperature sensor is activated.</li> <li>-The overload is activated.</li> <li>-The motor is blocked.</li> <li>-The contactor on the hoist is out of order or disconnected.</li> <li>-The limit switch is activated.</li> <li>-Fault in the control circuit.</li> <li>-Fault in the power circuit.</li> </ul>	<ul style="list-style-type: none"> <li>-Verification.</li> <li>-Verification.</li> <li>-Wait for a drop in temperature.</li> <li>-Reduce the load.</li> <li>-Check.</li> <li>-Verification (maintenance).</li> <li>-Reconnect or replace it.</li> <li>-Have a competent person check it.</li> </ul>
The hoist does not descend	<ul style="list-style-type: none"> <li>-The fall-prevention system is engaged</li> <li>-The temperature sensor is activated</li> <li>-The overload is activated</li> <li>-The lack of load is activated (optional)</li> <li>-The motor is blocked</li> <li>-The contactor in the hoist is out of order or disconnected</li> <li>-Fault in the control circuit</li> <li>-Fault in the power circuit</li> </ul>	<ul style="list-style-type: none"> <li>-Verification</li> <li>-Wait for a drop in temperature</li> <li>-Reduce the load</li> <li>-Check then press the red button of each hoist.</li> <li>-Check the motor</li> <li>-Reconnect or replace it</li> <li>-Have a competent person check it</li> </ul>



<p>The motor is powered but stalls chugging)</p>	<ul style="list-style-type: none"> <li>-The brake without power is disconnected or out of order.</li> <li>-The starting condenser and the centrifugal coupler are disconnected or out of order (only for a single phase hoist).</li> <li>-The motor is blocked.</li> <li>-Fault or one phase missing in the power circuit</li> <li>-Supply lead section too small</li> </ul>	<ul style="list-style-type: none"> <li>-Reconnect the brake or change it</li> <li>-Verification</li> <li>-Verification (maintenance)</li> <li>-Check the power supply</li> <li>-Replace the power cable</li> </ul>
<p>The hoist does not lift the load</p>	<ul style="list-style-type: none"> <li>-The grooved pulley is worn or dirty.</li> <li>-The permanent condenser is out of order.</li> <li>-The starting condenser and the centrifugal coupler are disconnected or out of order (only for a single phase hoist)</li> <li>-The temperature sensor is activated</li> <li>-The overload is activated.</li> <li>-Fault or one phase missing in the power circuit.</li> <li>-Supply lead section too small.</li> </ul>	<ul style="list-style-type: none"> <li>-Verification</li> <li>-Verification</li> <li>-Verification</li> <li>-Wait for a drop in temperature</li> <li>-Reduce the load</li> <li>-Check the power supply</li> <li>-Replace the supply lead</li> </ul>
<p>Current too high</p>	<ul style="list-style-type: none"> <li>-The brake without power is disconnected or out of order.</li> <li>-The permanent condenser is disconnected or out of order.</li> <li>-The motor is blocked.</li> </ul>	<ul style="list-style-type: none"> <li>-Reconnect the brake or change it.</li> <li>-Reconnect the condenser or change it.</li> <li>-Verifications (maintenance).</li> </ul>
<p>Slow sliding</p>	<ul style="list-style-type: none"> <li>-The grooved pulley is worn or dirty.</li> <li>-The brake without power is worn.</li> <li>-The adherence system is worn or dirty.</li> </ul>	<ul style="list-style-type: none"> <li>-Verification.</li> <li>-Replace the brake.</li> <li>-Verification.</li> </ul>
<p>Uncontrolled manual descent</p>	<ul style="list-style-type: none"> <li>-The manual lowering condenser is worn.</li> </ul>	<ul style="list-style-type: none"> <li>-Replace the condenser.</li> <li>-Check the contactor in K1 and K2.</li> </ul>
<p>Manual descent not possible</p>	<ul style="list-style-type: none"> <li>-The brake without power is jammed.</li> <li>-The fall-prevention system is jammed.</li> <li>-The load below the hoist is too little to initiate the movement</li> </ul>	<ul style="list-style-type: none"> <li>-Verification.</li> <li>-Use the hand wheel.</li> </ul>

## 11-Maintenance



**DANGER!**

<b>Risk of wounds injuries or death due to fall of objects, fall from different level, breaks and/or electric contact.</b>	Danger of death due to fall of objects, fall from different level and / or breaks. Danger of death by electric contact.
	-Stop the works immediately. -Identify the cause and solution the breakdown. -Before the works disconnect the power supply plug (CEE) of the platform. The worker must verify in every moment that the plug is disconnected.

Take into account the maintenance work and intervals described below:

Interval	Work	Execution
Daily	-Check lift attachment. -Check the SECURICHUTE600 fall arrester, see section 11.4. -Check for dirt on the wire rope. -Proof of operation, see section 6.6	User
Weekly	-Check wire rope, see section 11.2.1. -Check connection hose and control hose	User
1 time per year	-Check of complete security of the equipment	ACCESUS or a workshop authorized by ACCESUS
when necessary	-Clean, lubricate and / or replace the wire rope, see section 11.2 and 8.9. -Clean the lift, see section 11.1 and 11.3. -Clean the limit switches, lubricate the limit switch drive. -Lubricate the traction device.	A person named and formed by the operator

### 11.1-Wire ropes

Only the wire ropes recommended and supplied by ACCESUS guarantee the operation of the lifts

Cleaning: If necessary, brush dry, dirty wire ropes and, if necessary, grease them again.

NEVER CLEAN WIRE ROPES WITH HIGH PRESSURE WATER!

Greased: Lifting wire ropes should be greased regularly. To do this use IGOL SHP 50 grease or equivalent and distribute it by means of a cloth along the length of the wire rope.

NEVER LUBRICATE THE CABLE WITH LUBRICANTS CONTAINING BISULPHITES! (eg Molycote).

#### 11.2.1-Replacing the wire ropes

Only wire ropes recommended and supplied by ACCESUS guarantees the start up of the hoists safely

The wire rope has a nominal pipe size of 8,3mm, a hook with a safety clip in one end and a rounded tip at the other side. The wire rope has a nameplate which identifies the origin, diameter and length.

The wire rope must be replaced in this cases:

a) Reduction of the diameter. Minimum diameter 7,4 mm (for a wire rope with a nominal pipe size of 8,3 mm).

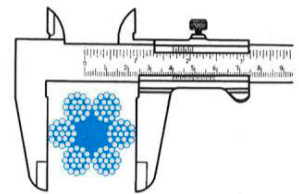
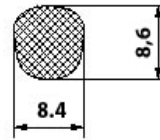

b) Breaking of more than 10 threads over a length of 25 cm for a wire rope of Ø8,3 mm.

c) Deformity or breaking of his clamps.

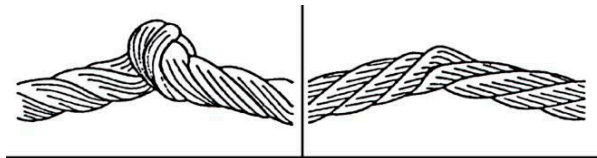

d) Wire rope crushed or stripped.

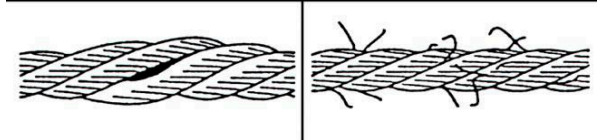

e) Hard oxidation.

### 11.2-Elevator

No maintenance is required on the engine, gear or brake until it reaches the annual review interval.

-In case of dirt, clean from the outside.

-Keep brake free of oil and grease.

### 11.3-Fall arrest device securichute

Control regularly the correct start up of the fall arrest devices securichute600.

If the fall arrest device doesn't works correctly when performing the following tests, it must be replaced and repaired immediately by ACCESUS or by an authorized repairer.

#### 1- Diary verification:

Verify that the securichute600 holds correctly the secondary wire rope.

- Press the emergency stop button.  
The clamps must closes automatically and be impossible to take out the wire rope manually.

- Reset the securichute600 pressing the reset handle. The safety wire rope must flows freely inside the fall arrest device securichute600

#### 2-Weekly verification weekly:

With the platform on the ground:

- Pull up, with a strong and quick blow, the safety wire rope.  
The securichute600 must subject immediately the wire rope. Repeat this operation at least 3 consecutive times.

- Reset the securichute600 by actuating his reset handle.

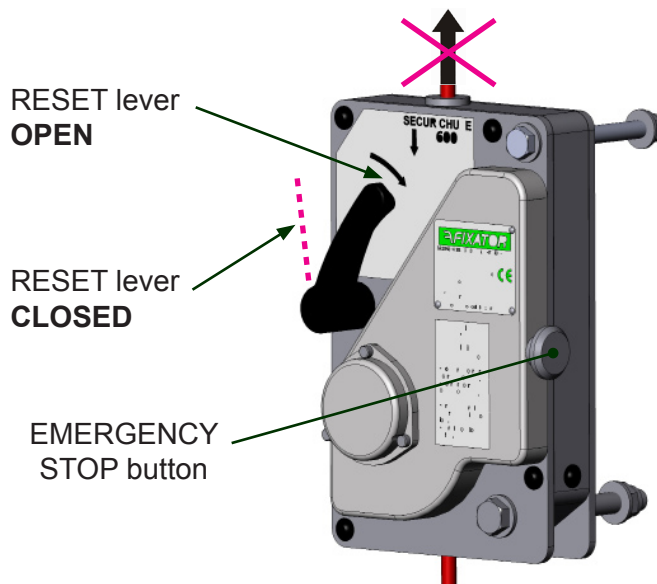

## 12-Spare parts

### 12.1-komplet 211062 platform

Indicate model, serial number and description of the platform.

### 12.2-Electric hoist e.lift501

Indicate model, serial number and description of the hoist.

### 12.3-Fall arrest device securichute600

Indicate model, serial number and description of the fall arrest device.

### 12.4-Electric cabinet

Indicate model, serial number and description of the electric cabinet. The electric scheme is inside the electric cabinet.

### 12.5-Nameplates and labels

Check the location of the labels.

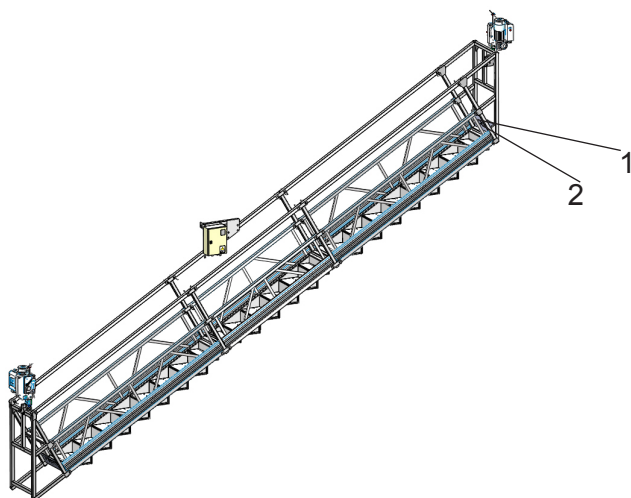

Platform nameplate (1)

Modelo / Model ref.: 211062-001E

**KOMPLET 211062**

Nº serie / Serial nº **211062-2001**

Año / Year **2020**

Nº de personas / Number of people	3
Capacidad de carga / Loading capacity	320kg
Peso propio / Empty weight	550kg

Fabricante / manufacturer



c/Energia 54  
08940 Cornellà de Llobregat, Barcelona-SPAIN  
Telf.: (+34) 93 475 17 73  
accessus@accessus.es    www.accessus.es

Warnings label (2)

#### WARNINGS OF USE

- This platform is destined for a professional use only. Only people with an adequate training and suitable for works at heights are authorized.
- For safety, it's essential for the worker to know and apply the instructions described at the Instructions Manual delivered with the platform.
- Don't exceed the Weight Load Limit or the number of people indicated at the platform's nameplate.
- Stop the works and put the platform on the ground if wind's velocity exceeds 14m/sec if it's a non guided platform or 16m/sec if it's a guided platform. Don't work with storm weather.
- If it's raining verify the engine's brake of the e.lift in order to avoid glidings.
- Before each start up, the machine must be verified by a competent person.
- A maintenance operation must be realized annually by Accessus.



ref.: 020020-000

### 13-Disposal and environmental protection

The equipment is made from recyclable materials. If the equipment is later scrapped, it must be disposed off correctly. The national versions of the waste legislation Directive 75/442/CEE apply within the European Union.

In accordance with Directive 2002/96/CE, the manufacturer is obliged to take back and dispose of specific pneumatic and electronic components. The following symbol is used on the nameplate of such components to identify them:





## 14-Model for Declaration of Conformity

**Declaración « CE » de conformidad**

Conforme al anexo II. 1. A de la Directiva Máquinas 2006/42/CE  
**Plataforma suspendida temporal (TSP)**

Modelo: **PLATAFORMA KOMPLET 211062**  
 N° Serie: **211062-XXX**

La sociedad fabricante: **ACCESUS PLATAFORMAS SUSPENDIDAS, S.L.**  
 C/Energía 54  
 08940 Cornellá de Llobregat, Barcelona-SPAIN  
 Telf.: (+34) 93 475 17 73  
 Email: [accesus@accesus.es](mailto:accesus@accesus.es)  
 Web: [www.accesus.es](http://www.accesus.es)

Declara que la plataforma suspendida temporal (TSP) mencionada, cumple con todas las disposiciones aplicables de la Directiva Europea 2006/42/CE relativa a las máquinas y las reglamentaciones nacionales que la transponen;

Cumple las disposiciones de las siguientes normas armonizadas: EN ISO 12100:2010 y UNE-EN 1808:2015.

Los datos de la persona facultada para elaborar el expediente técnico son:

XXXXXXXXXXXX  
 XXXXXXXXXXXX  
 XXXXXXXXXXXXXXXXXXXX

Firma del apoderado declarante:

Nombre: XXXXXXXXXXXXXXXX  
 Cargo: XXXXXXXXXXXXXXXX  
 Lugar y fecha de la firma: XXXXXXXXXXXXXXXX, a XX/0X/20XX

Firma:



**accesus**  
 PLATAFORMAS SUSPENDIDAS

## 15-Machine's historic

Indicate the Serial Number of the machine and his components.

Machine or component	Serial number
KOMPLET 211062 suspended platform	
e.lift501 Powered hoist	/
Securichute600 fall arrest device	/
Electric cabinet	
Date of start up	

Date	Maintenance according to ecc.11	Condition <b>OK</b>	Condition <b>NOT OK</b>	Identification and signature

### 15.1-Daily inspection report

This inspection report is indicative, in no circumstances Accesus will be responsible for the content or annotations.

It is mandatory to read and assimilate the instructions in the user manual before proceeding with the platform use or maintenance.

Responsible of the Inspection		
Company		
Date		
Location		
Indicate the machine serial number and its he components.		
	Model	Serial number
Platform		
Elevator 1		
Elevator 2		
Fall arrest device 1		
Fall arrest device 2		
Electric cabinet		
Electric cabinet		
	Elevator / Fall arrest device 1	Elevator / Fall arrest device 2
Wire ropes (work)	(1) Length:	(3) Length:
Wire ropes (safety)	(2) Length:	(4) Length:

Ref.	Description	Compliance	NOT Compliance		Comments
			Repairable	NOT repairable	
1	Platform				
1.1	Clean up				
1.2	Welds				
1.3	Handrails				
1.4	Floor panels				
1.5	Limit switch sensor				
1.6	End fixed disk				
2	Elevator 1				
2.1	Clean up				
2.2	Noise				
2.3	Vibrations				
2.4	Plug				
3	Elevator 2				
3.1	Clean up				
3.2	Noise				
3.3	Vibrations				
3.4	Plug				

Ref.	Description	Compliance	NOT Compliance		Comments
			Repairable	NOT repairable	
4	Fall arrest device 1				
4.1	Clean up				
4.2	Emergency stop				
5	Fall arrest device 2				
5.1	Clean up				
5.2	Emergency stop				
6	Electric cabinet				
6.1	Emergency stop				
7	Wire rope 1				
7.1	Hook and locking				
7.2	Wear				
8	Wire rope 2				
8.1	Hook and locking				
8.2	Wear				
9	Wire rope 3				
9.1	Hook and locking				
9.2	Wear				
10	Wire rope 4				
10.1	Hook and locking				
10.2	Wear				
11	Electric hose				
11.1	Plugs and connections				

**In case of detecting one or more not compliance points, the platform must be immobilized and prevented from being used until the detected defects are solved.**

### 15.2-Periodic inspection report

This inspection report is indicative, in no circumstances Accesus will be responsible for the content or annotations.

It is mandatory to read and assimilate the instructions in the user manual before proceeding with the platform use or maintenance.

Responsible of the Inspection		
Company		
Date		
Location		
Indicate the machine serial number and its he components.		
	Model	Serial number
Platform		
Elevator 1		
Elevator 2		
Fall arrest device 1		
Fall arrest device 2		
Electric cabinet		
	Elevator / Fall arrest device 1	Elevator / Fall arrest device 2
Wire rope (work)	(1) Length:	(3) Length:
Wire rope (safety)	(2) Length:	(4) Length:

Ref.	Description	Compliance	NOT Compliance		Comments
			Repairable	NOT repairable	
1	Platform				
1.1	Clean up				
1.2	Welds				
1.3	Handrails				
1.4	Floor panels				
1.5	Limit switch sensor				
1.6	End fixed disk				
2	Elevator 1				
2.1	Clean up				
2.2	Crankcase				
2.3	Connection box				
2.4	Functioning of brakes				
2.5	Noise				
2.6	Vibrations				
2.7	Fixing screws				
2.8	Plug				
3	Elevator 2				
3.1	Clean up				
3.2	Crankcase				

Ref.	Description	Compliance	NOT Compliance		Comments
			Repairable	NOT repairable	
3.3	Connection box				
3.4	Functioning of brakes				
3.5	Noise				
3.6	Vibrations				
3.7	Fixing screws				
3.8	Plus				
4	Fall arrest device 1				
4.1	Clean up				
4.2	Emergency stop				
5	Fall arrest device 2				
5.1	Clean up				
5.2	Emergency stop				
6	Electric cabinet				
6.1	Emergency stop				
6.2	Limit switch sensor				
7	Wire rope (1)				
7.1	Diameter				
7.2	Hook and locking				
7.3	Wear				
7.4	Broken threads				
7.5	End				
8	Wire rope (2)				
8.1	Diameter				
8.2	Hook and locking				
8.3	Wear				
8.4	Broken threads				
8.5	End				
9	Wire rope (3)				
9.1	Diameter				
9.2	Hook and locking				
9.3	Wear				
9.4	Broken threads				
9.5	End				
10	Wire rope (4)				
10.1	Diameter				
10.2	Hook and locking				
10.3	Wear				
10.4	Broken threads				
10.5	End				

Ref.	Description	Compliance	NOT Compliance		Comments
			Repairable	NOT Repairable	
11	Electric hoses				
11.1	Plugs and connections				
11.2	Cut				
11.3	Junction				
11.4	Mountings				
11.5	Proper section				

**In case of detecting one or more not compliance points, the platform must be immobilized and prevented from being used until the detected defects are solved.**

**The elevators, the fall arrest systems and electric cabinet must be checked by Accesus once a year.**



 **accessus**  
PLATAFORMAS SUSPENDIDAS  
C/Energia 54  
08940 Cornellà de Llobregat  
Barcelona - Spain  
Telf.: (+34) 93 475 17 73  
[www.accessus.es](http://www.accessus.es) [accessus@accessus.es](mailto:accessus@accessus.es)